

LIST OF PARTS

DESCRIPTION	MATERIAL	FINISH
SPACER	STEEL	GALVANIZED
SIDES	STEEL	GALVANIZED
FASTENERS	STEEL	GALVANIZED
CLAMPS	STEEL	GALVANIZED

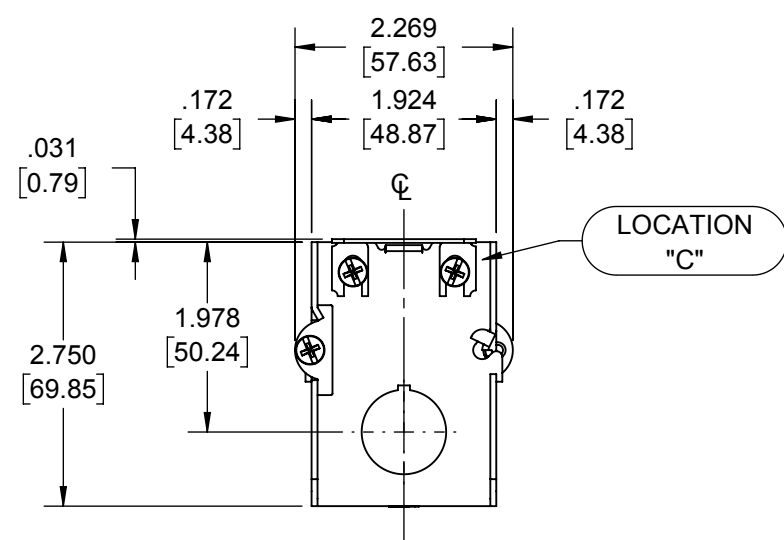
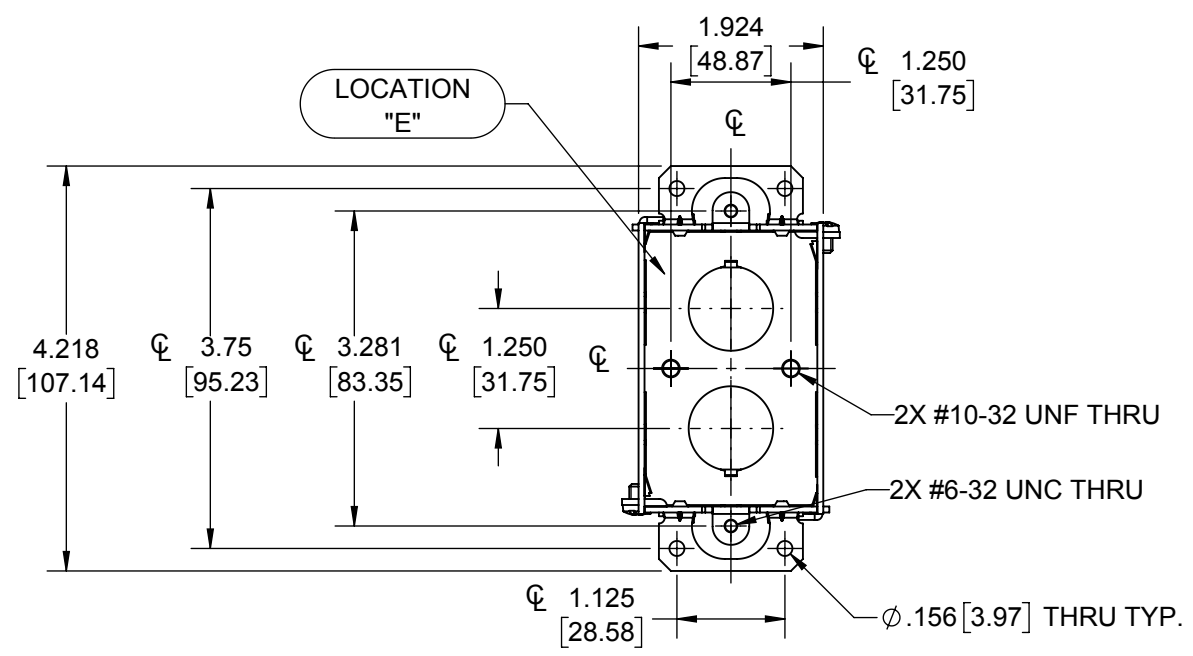
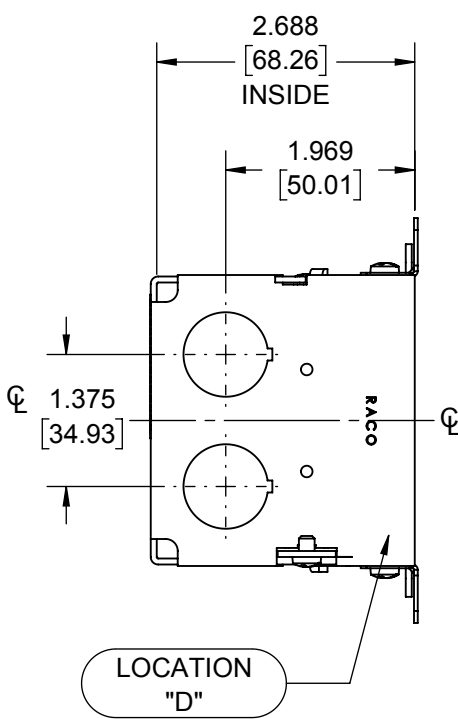
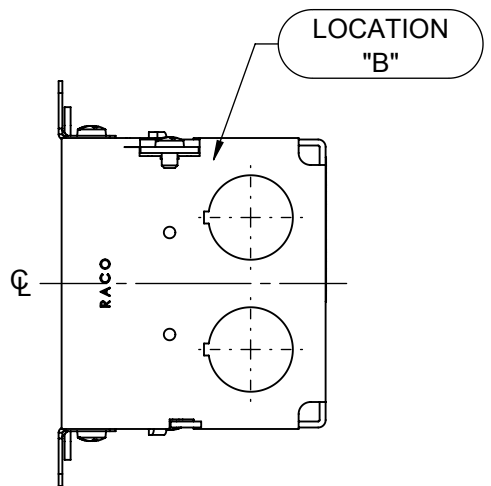
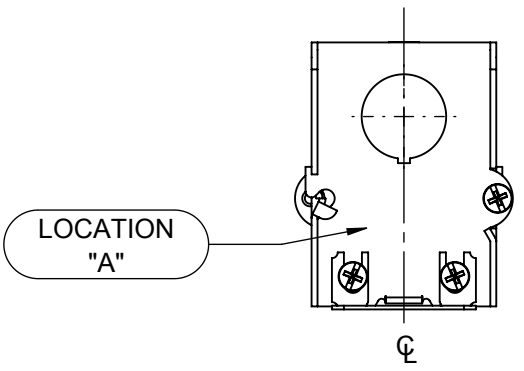
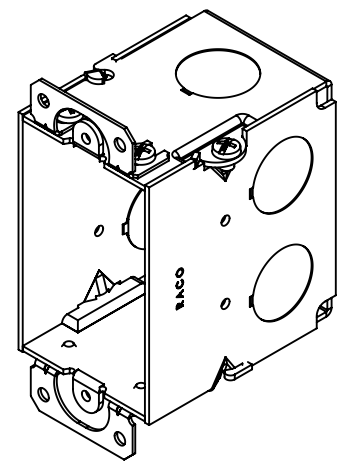

INITIAL RELEASE	RMV	03-02-18
SYM.	REVISION DESCRIPTION	APP DATE

THE DESIGN AND DIMENSIONS OF THE PRODUCT SHOWN ON THIS DRAWING ARE SUBJECT TO CHANGE WITHOUT NOTICE

TITLE: **SWITCH BOX: 3" X 2" X 2 3/4" DP. w/ 1/2" KO'S & EARS**

KNOCKOUTS		
TRADE SIZE	LOCATION	QTY.
1/2" KO	A, C	1
1/2" KO	B, D, E	2

TOLERANCE UNLESS OTHERWISE SPECIFIED

.XX DECIMAL ±.015
.XXX DECIMAL ±.005
ANGLE ±2°

RACO
South Bend, Indiana

DRAWN BY:	RMV	SCALE:
APP. BY:	N.S.	1:2
DATE:	03-02-18	

NOTES:
1. ALL DIMENSIONS ARE IN INCHES AND [MILLIMETERS]
2. BOX VOLUME: 14.0 IN³ [229.4 CM³]
3. UL LISTED