

REVISIONS			
REV.	DATE	DESCRIPTION	BY
-	12-16-21	INITIAL RELEASE	RMV

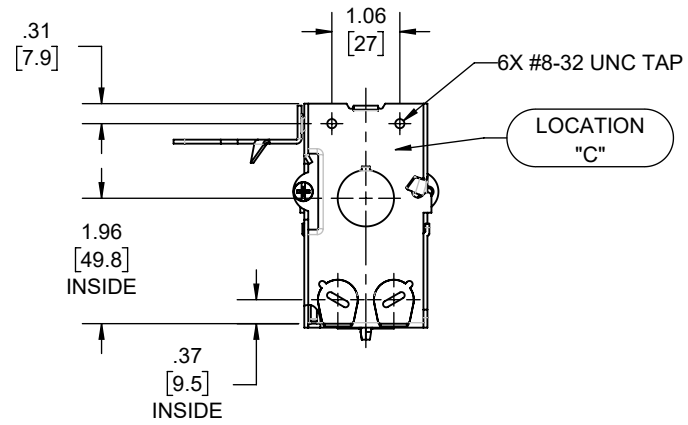
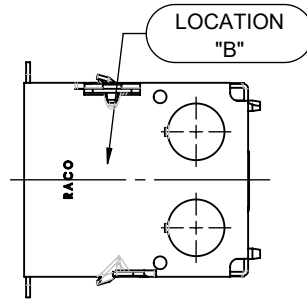
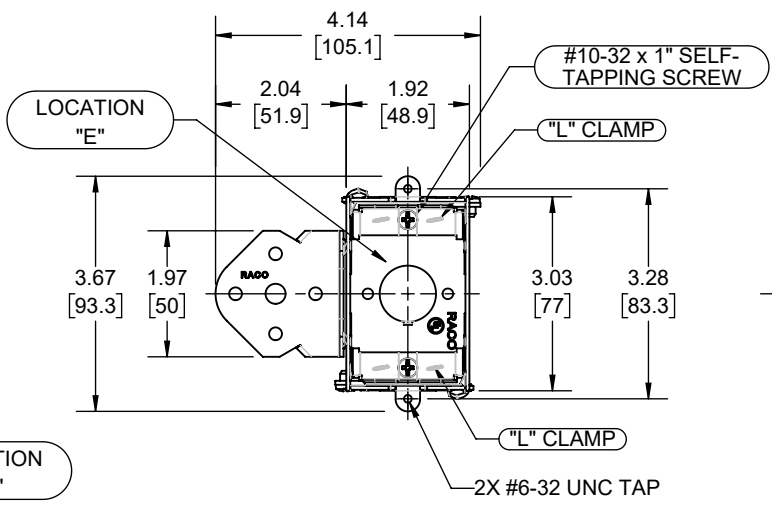
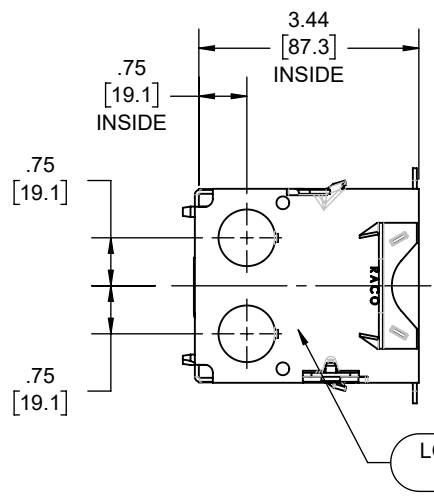
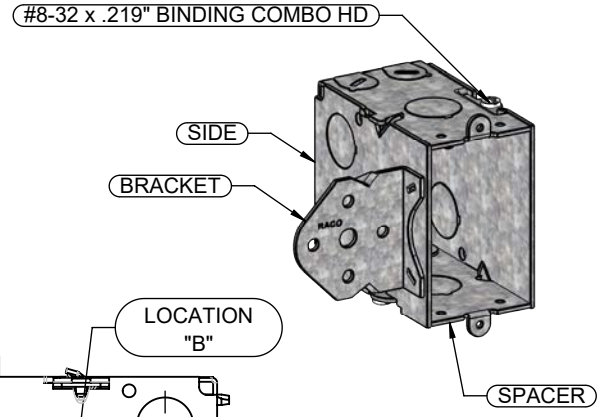
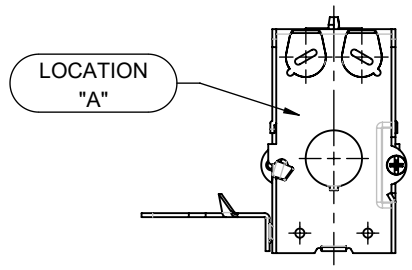

DESCRIPTION	MATERIAL	FINISH
BRACKETS	STEEL	GALVANIZED
CLAMPS	STEEL	GALVANIZED
FASTENERS	STEEL	GALVANIZED
SIDE	STEEL	GALVANIZED
SPACER	STEEL	GALVANIZED

LIST OF PARTS

THE DESIGN AND DIMENSIONS OF THE PRODUCT SHOWN ON THIS DRAWING ARE SUBJECT TO CHANGE WITHOUT NOTICE

TITLE:
3-1/2 DP SW BOX, B-BRKT, "L" CLAMPS, 1/2 KO

KNOCKOUTS		
TRADE SIZE	LOCATION	QTY.
1/2" KO	A, C, E	2
1/2" KO	B, D	1
PRI-OUTS	A, C	2

TOLERANCE UNLESS OTHERWISE SPECIFIED .XX DECIMAL ± .015 .XXX DECIMAL ± .005 ANGLE ± 2°			SCALE: 1:3
	DRAWN BY: RMV	APP. BY: N.S.	
	DATE: 12-16-21	SIZE: A	

- NOTES:
- ALL DIMENSIONS ARE IN INCHES AND [MILLIMETERS]
 - BOX VOLUME: 18.0 IN³ [295.0 CM³]
 - UL LISTED