

LIST OF PARTS

DESCRIPTION	MATERIAL	FINISH
SPACER	STEEL	GALVANIZED
SIDES	STEEL	GALVANIZED
PLASTER EARS	STEEL	GALVANIZED
OLD WORK CLIPS	STEEL	GALVANIZED
FASTENERS	STEEL	GALVANIZED
STAB-IT™ CLAMP	STEEL	GALVANIZED
PIG TAIL	COPPER	

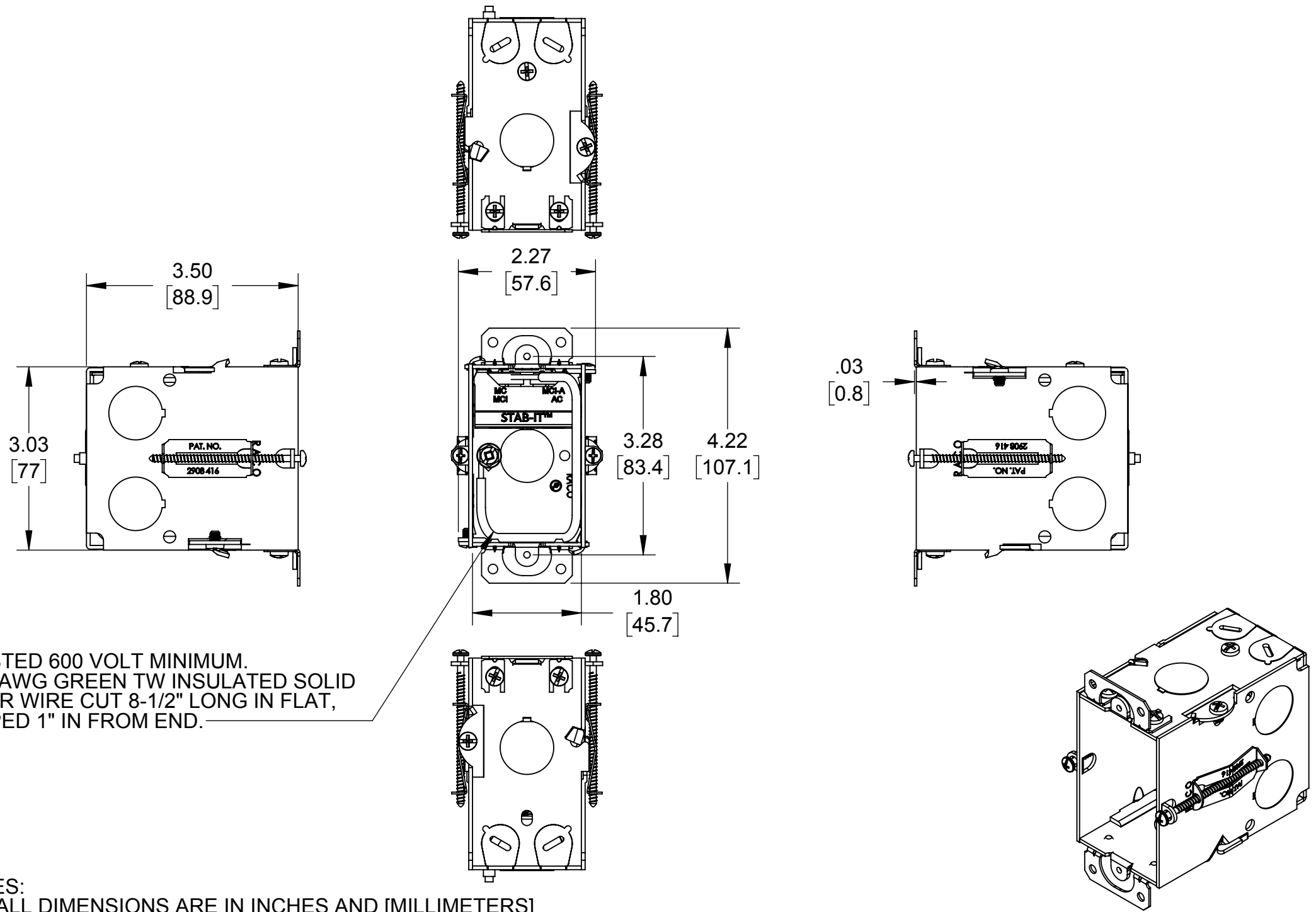

U.L. LISTED 600 VOLT MINIMUM.
NO. 12 AWG GREEN TW INSULATED SOLID
COPPER WIRE CUT 8-1/2" LONG IN FLAT,
STRIPPED 1" IN FROM END.

- NOTES:
1. ALL DIMENSIONS ARE IN INCHES AND [MILLIMETERS]
 2. BOX VOLUME: 18.0 IN³ [295 CM³]
 3. 1 #12AWG SOLID COPPER WIRE 8" LONG PIG TAIL WITH GROUNDING SCREW INCLUDED
 4. UL LISTED

KNOCKOUTS	
TRADE SIZE	LOCATION
1/2" KO	1- ON THE BOTTOM (ACCESSIBLE AFTER REMOVAL STAB-IT CLAMP)
	2- ON EACH SIDE(1 ACCESSIBLE ONLY AFTER REMOVAL STAB-IT CLAMP)
CABLE PRIOUTS	2- ON EACH SIDE OF THE SPACER

CABLE TYPES AND RANGES FOR STAB-IT CLAMP	
CABLE TYPES	CABLE RANGES
AC STEEL & ALUMINIUM	14-2,14-3,14-4,12-2,12-3,12-4,10-2,10-3
HCF AC STEEL	14-2,14-3,14-4,12-2,12-3,10-2,10-3
HCF AC ALMINUM	12-2,12-3,12-4,10-2,10-3
MC STEEL & ALUMINIUM	14-2,14-3,14-4,12-2,12-3,12-4,10-2,10-3
MCI-A STEEL & ALUMINIUM	14-2,14-3,14-4,12-2,12-3,12-4,10-2,10-3
HCF MCI-A STEEL	12-2,12-3,10-2
HCF MCI-A ALUMINIUM	14-2,14-3,14-4,12-2,12-3,12-4,10-2,10-3
3/8 TRADE SIZE FLEX,REFMC CONDUIT STEEL & ALUMINIUM. ANTI SHORT BUSHING REQUIRED	
CABLE RANGE .400" DIA. MIN TO .605" DIA. MAX	

INITIAL RELEASE	K.K.	DATE

THE DESIGN AND DIMENSIONS OF THE PRODUCT SHOWN ON THIS DRAWING ARE SUBJECT TO CHANGE WITHOUT NOTICE

TITLE:
3-1/2" " DEEP GANGABLE OLD WORK SWITCH BOX WITH STAB-IT® BX/MC CABLE CLAMP

TOLERANCE UNLESS OTHERWISE SPECIFIED		<p>RACO South Bend, Indiana</p>	SCALE: 1:2
.XX DECIMAL ±.015	DRAWN BY: K.K.		
.XXX DECIMAL ±.005	APP. BY: N.S.		
ANGLE ±2°	DATE: 10/07/2016		