

LIST OF PARTS

DESCRIPTION	MATERIAL	FINISH
SPACER	STEEL	GALVANIZED
SIDES	STEEL	GALVANIZED
BRACKET	STEEL	GALVANIZED

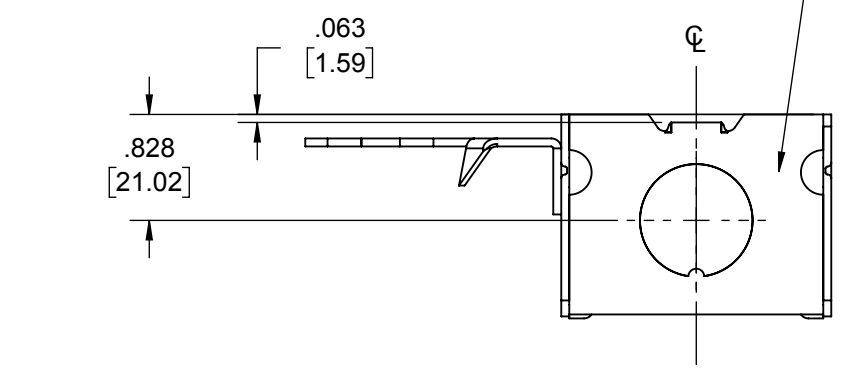
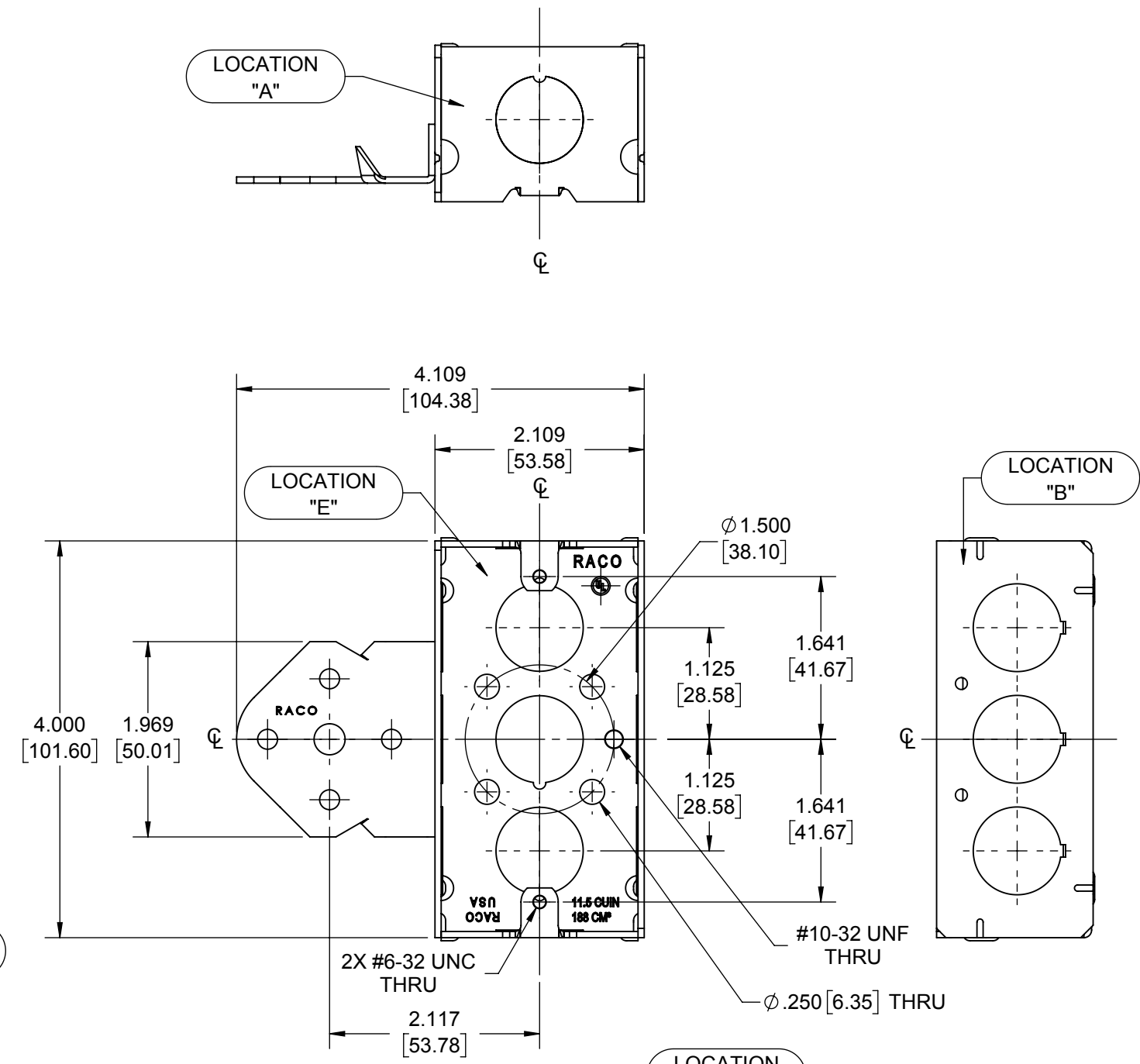
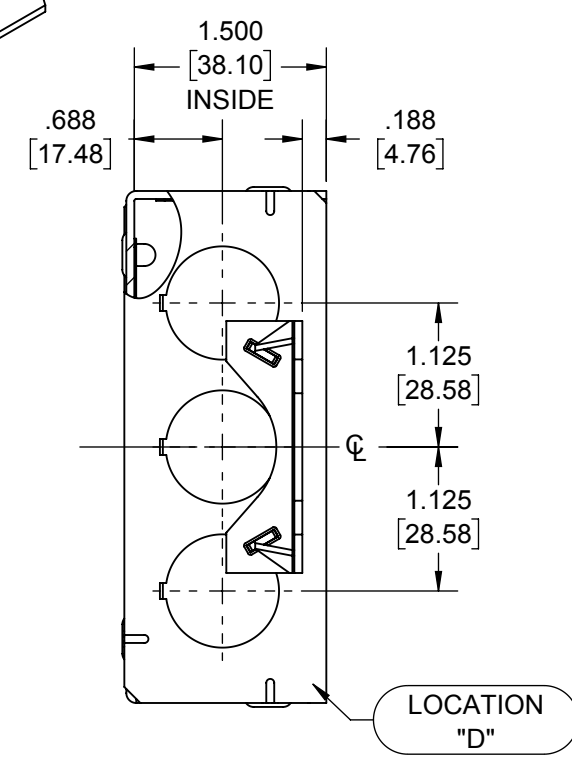
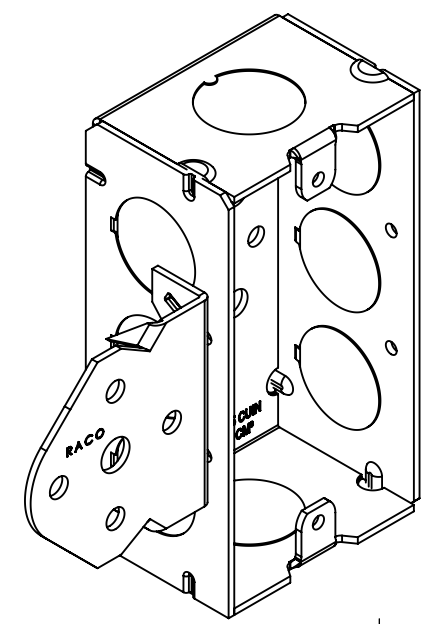

KNOCKOUTS		
TRADE SIZE	LOCATION	QTY.
1/2" KO	B, D, E	3
1/2" KO	A, C	1

TOLERANCE UNLESS OTHERWISE SPECIFIED
.XX DECIMAL ±.015
.XXX DECIMAL ±.005
ANGLE ±2°

RACO
South Bend, Indiana

DRAWN BY:	RMV	SCALE:
APP. BY:	N.S.	1:1.5
DATE:	03-06-18	

INITIAL RELEASE	RMV	03-06-18
SYM.	REVISION DESCRIPTION	APP DATE

THE DESIGN AND DIMENSIONS OF THE PRODUCT SHOWN ON THIS DRAWING ARE SUBJECT TO CHANGE WITHOUT NOTICE

TITLE:
4" X 1.5" DEEP WELDED BOX W/ (11) 1/2" KO'S (UL) & "COB" BRACKET

- NOTES:
1. ALL DIMENSIONS ARE IN INCHES AND [MILLIMETERS]
2. BOX VOLUME: 11.5 IN³ [188.5 CM³]
3. UL LISTED