

REVISIONS			
REV.	DATE	DESCRIPTION	BY:
-	07-02-19	INITIAL RELEASE	RMV

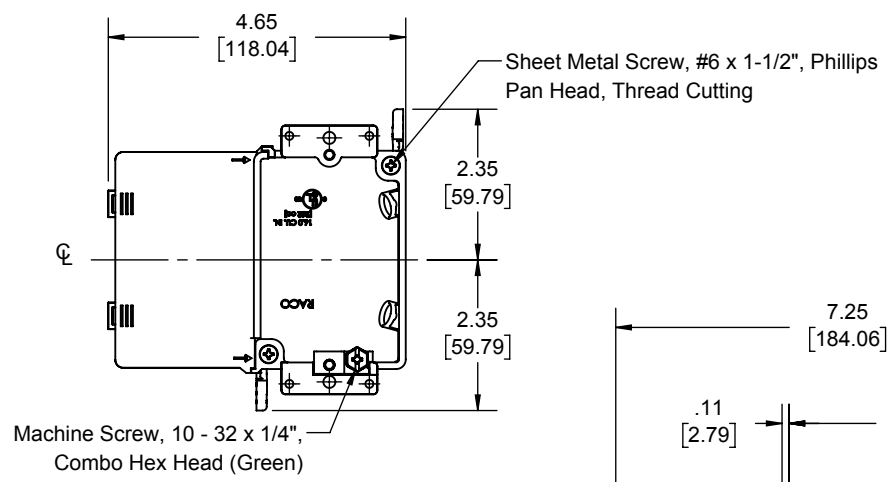

CLOSED
SCALE 1:3

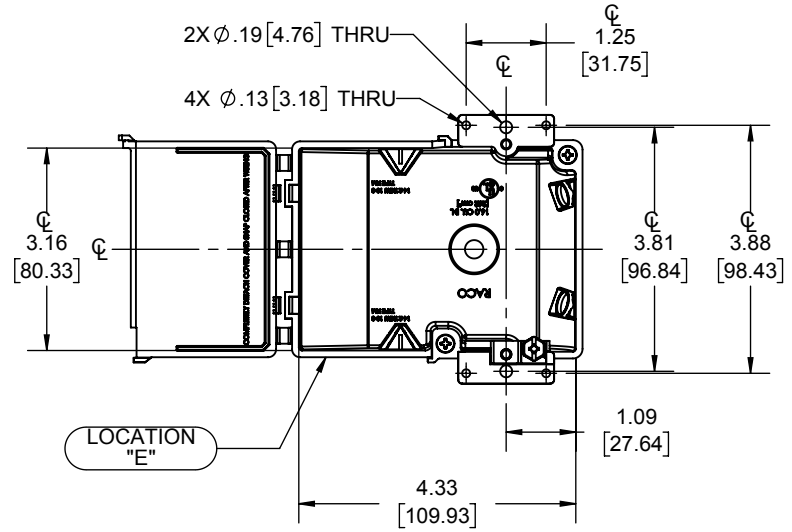
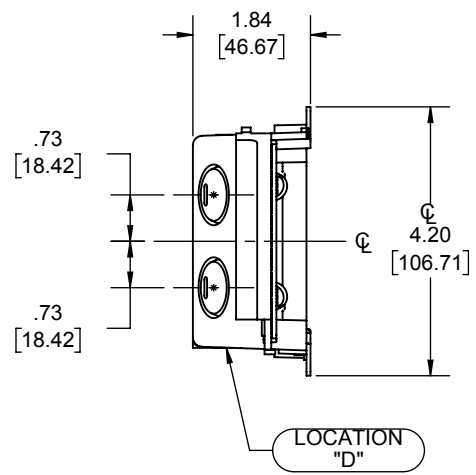
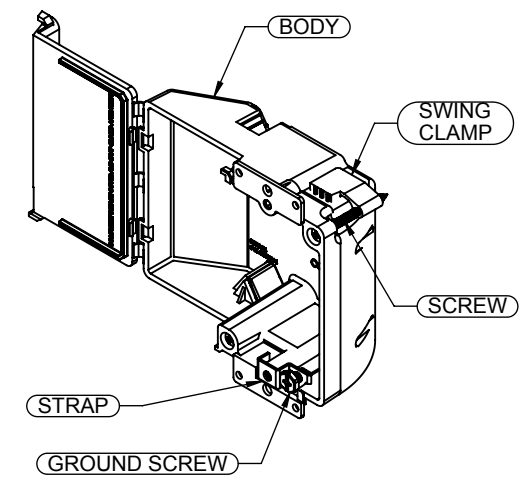
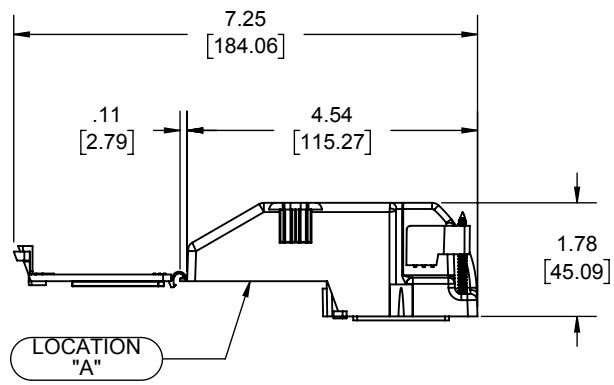

DESCRIPTION	MATERIAL	FINISH
STRAP	STEEL	GALVANIZED
FASTENERS	STEEL	GALVANIZED
SWING CLAMPS	NORYL PLASTIC	-
BODY	NORYL PLASTIC	-

LIST OF PARTS

THE DESIGN AND DIMENSIONS OF THE PRODUCT SHOWN ON THIS DRAWING ARE SUBJECT TO CHANGE WITHOUT NOTICE

TITLE:
ELECTRICAL BOX, 1G, SHALLOW WALL, OLD WORK

- NOTES:
1. ALL DIMENSIONS ARE IN INCHES AND [MILLIMETERS]
 2. BOX VOLUME: 16.0 IN³ [262.2 CM³]
 3. cULus LISTED
 4. CABLE SIZES: 14-2 THRU 10-3 TYPE NM

KNOCKOUTS		
TRADE SIZE	LOCATION	QTY.
1/2" KO	D	2

TOLERANCE UNLESS OTHERWISE SPECIFIED

.XX DECIMAL ± .015
.XXX DECIMAL ± .005
ANGLE ± 2°

DRAWN BY:	RMV	SCALE:	SIZE:
APP. BY:	N.S.	1:3	A
DATE:	07-02-19		