

REVISIONS			
REV.	DATE	DESCRIPTION	BY:
-	07-02-19	INITIAL RELEASE	RMV

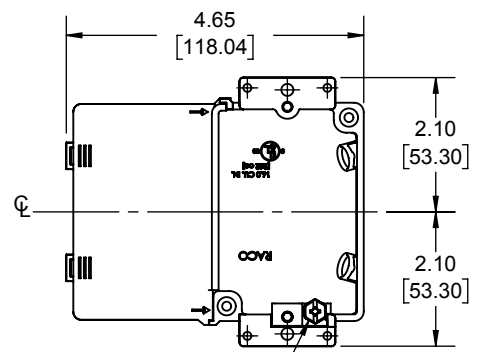

Machine Screw, 10 - 32 x 1/4",  
Combo Hex Head (Green)

**CLOSED**  
**SCALE 1:3**

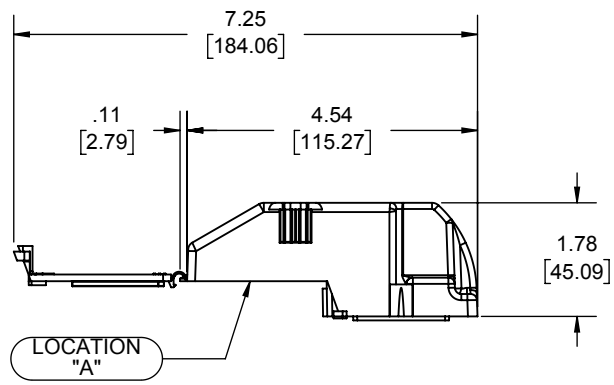

LOCATION "A"

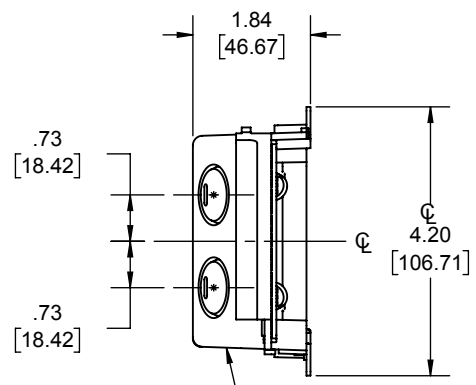
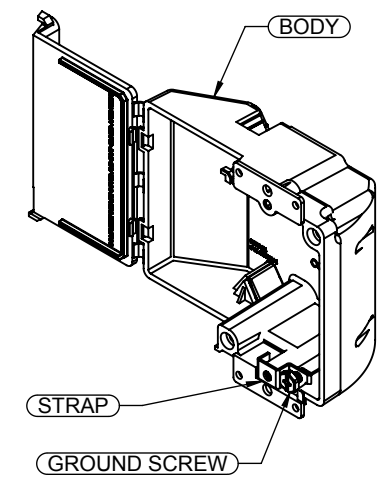

LOCATION "D"

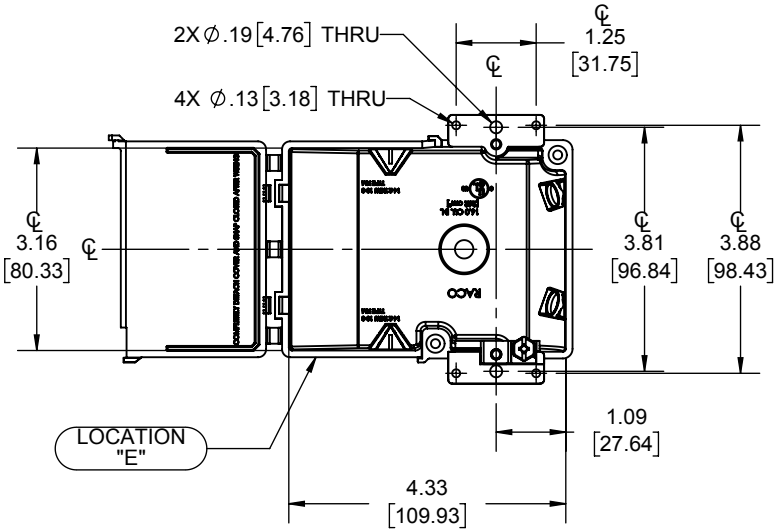

LOCATION "E"

DESCRIPTION	MATERIAL	FINISH
FASTENERS	STEEL	GALVANIZED
SWING CLAMPS	NORYL PLASTIC	-
BODY	NORYL PLASTIC	-

**LIST OF PARTS**

THE DESIGN AND DIMENSIONS OF THE PRODUCT SHOWN ON THIS DRAWING ARE SUBJECT TO CHANGE WITHOUT NOTICE

TITLE:  
**ELECTRICAL BOX, 1G, SHALLOW WALL**

- NOTES:
1. ALL DIMENSIONS ARE IN INCHES AND [MILLIMETERS]
  2. BOX VOLUME: 16.0 IN<sup>3</sup> [262.2 CM<sup>3</sup>]
  3. cULus LISTED
  4. CABLE SIZES: 14-2 THRU 10-3 TYPE NM

KNOCKOUTS		
TRADE SIZE	LOCATION	QTY.
1/2" KO	D	2

TOLERANCE UNLESS OTHERWISE SPECIFIED



.XX DECIMAL ± .015  
.XXX DECIMAL ± .005  
ANGLE ± 2°

DRAWN BY:	RMV	SCALE:	SIZE:
APP. BY:	N.S.	1:3	<b>A</b>
DATE:	07-02-19		