

REVISIONS			
REV.	DATE	DESCRIPTION	BY
-	05-09-23	INITIAL RELEASE	RMV

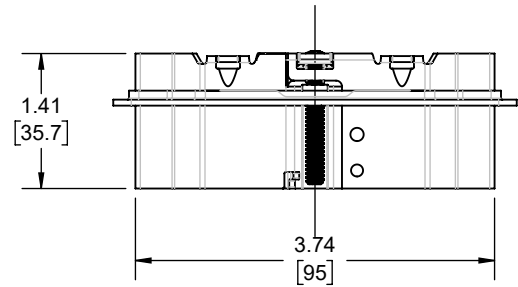
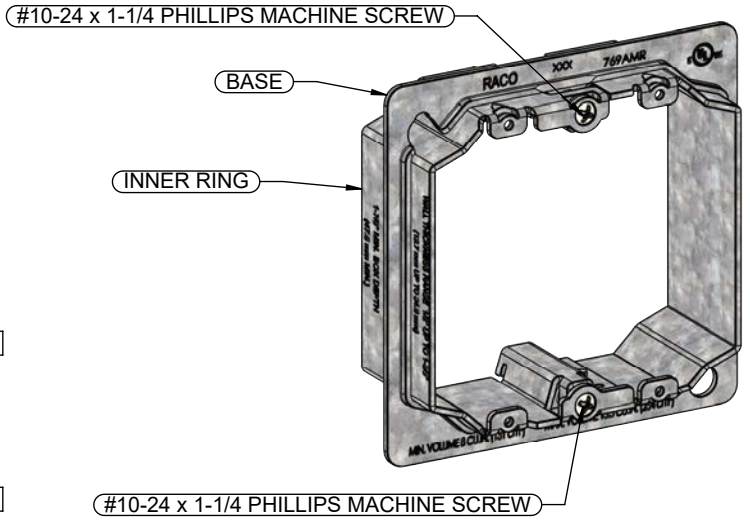
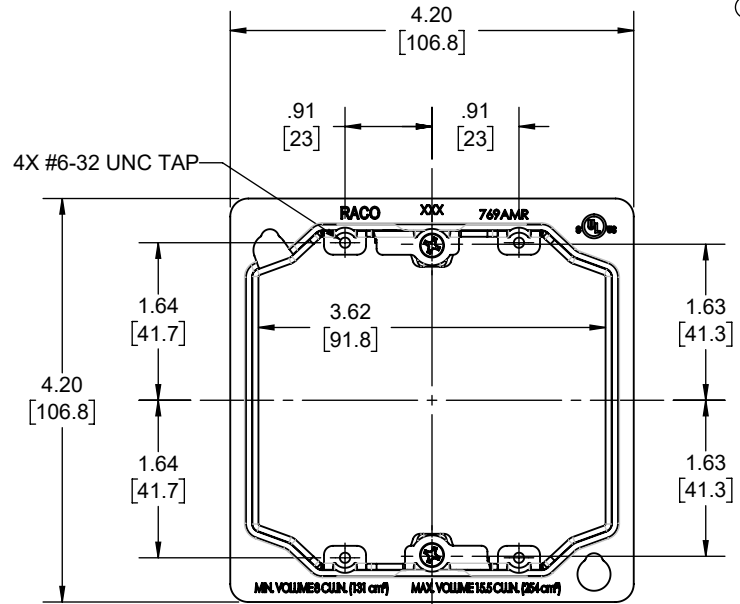
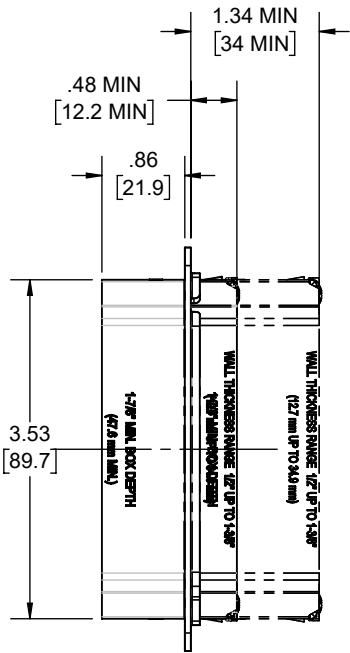

- NOTES:  
 1. ALL DIMENSIONS ARE IN INCHES AND [MILLIMETERS]  
 2. BOX VOLUME: 8.0 IN<sup>3</sup> [131.1 CM<sup>3</sup>] MIN.  
 15.5 IN<sup>3</sup> [254.0 CM<sup>3</sup>] MAX.  
 3. cULus LISTED

DESCRIPTION	MATERIAL	FINISH
FASTENERS	STEEL	GALVANIZED
INNER RING	STEEL	GALVANIZED
BASE	STEEL	GALVANIZED

LIST OF PARTS

THE DESIGN AND DIMENSIONS OF THE PRODUCT SHOWN ON THIS DRAWING ARE SUBJECT TO CHANGE WITHOUT NOTICE

TITLE:  
**DOUBLE GANG ADJUSTABLE MUD RING**

TOLERANCE UNLESS OTHERWISE SPECIFIED .XX DECIMAL ± .015 .XXX DECIMAL ± .005 ANGLE ± 2°			DRAWN BY:	RMV	SCALE:	SIZE:
			APP. BY:	N.S.		
	DATE:	05-09-23	1:2	A		