

| REVISIONS | | | |
|-----------|----------|-----------------|-----|
| REV. | DATE | DESCRIPTION | BY |
| - | 02-20-23 | INITIAL RELEASE | RMV |

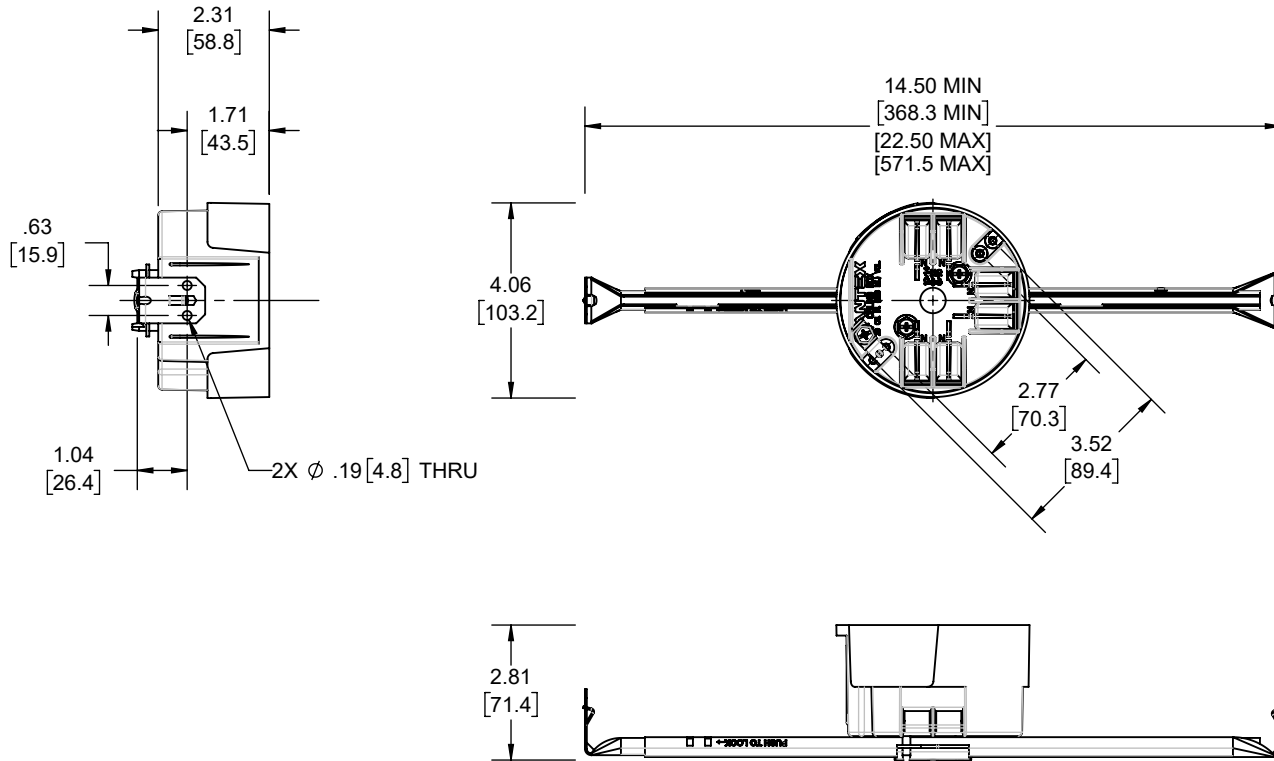
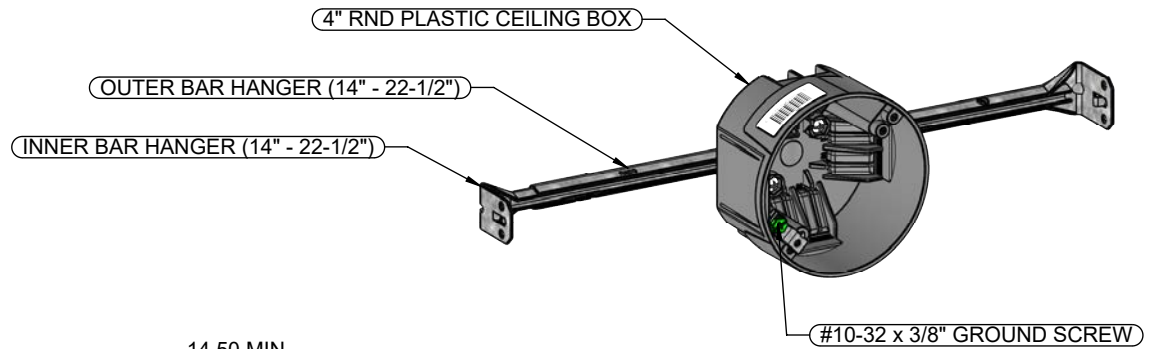

| DESCRIPTION | MATERIAL | FINISH |
|-------------|----------|------------|
| FASTENERS | STEEL | GALVANIZED |
| SPANNER BOX | STEEL | GALVANIZED |
| NM BOX | STEEL | BLACK |

LIST OF PARTS

THE DESIGN AND DIMENSIONS OF THE PRODUCT SHOWN ON THIS DRAWING ARE SUBJECT TO CHANGE WITHOUT NOTICE

TITLE:
**4 IN. ROUND NM BOX, 2-3/8" DP.,
SPANNER BAR W/ GROUND
STRAP**

| | | | | |
|---|-----------|------|------------|----------------|
| TOLERANCE UNLESS OTHERWISE SPECIFIED .XX DECIMAL ± .015 .XXX DECIMAL ± .005 ANGLE ± 2° | | | SCALE: 1:4 | SIZE: A |
| | DRAWN BY: | RMV | | |
| | APP. BY: | N.S. | | |
| DATE: | 02-20-23 | | | |

- NOTES:
1. ALL DIMENSIONS ARE IN INCHES AND [MILLIMETERS]
 2. VOLUME: 20.0 IN³ [327.7 CM³]
 3. UL LISTED