

REVISIONS			
REV.	DATE	DESCRIPTION	BY:
-	07-01-19	INITIAL RELEASE	RMV

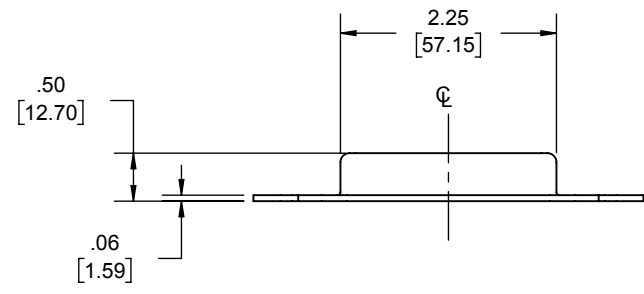
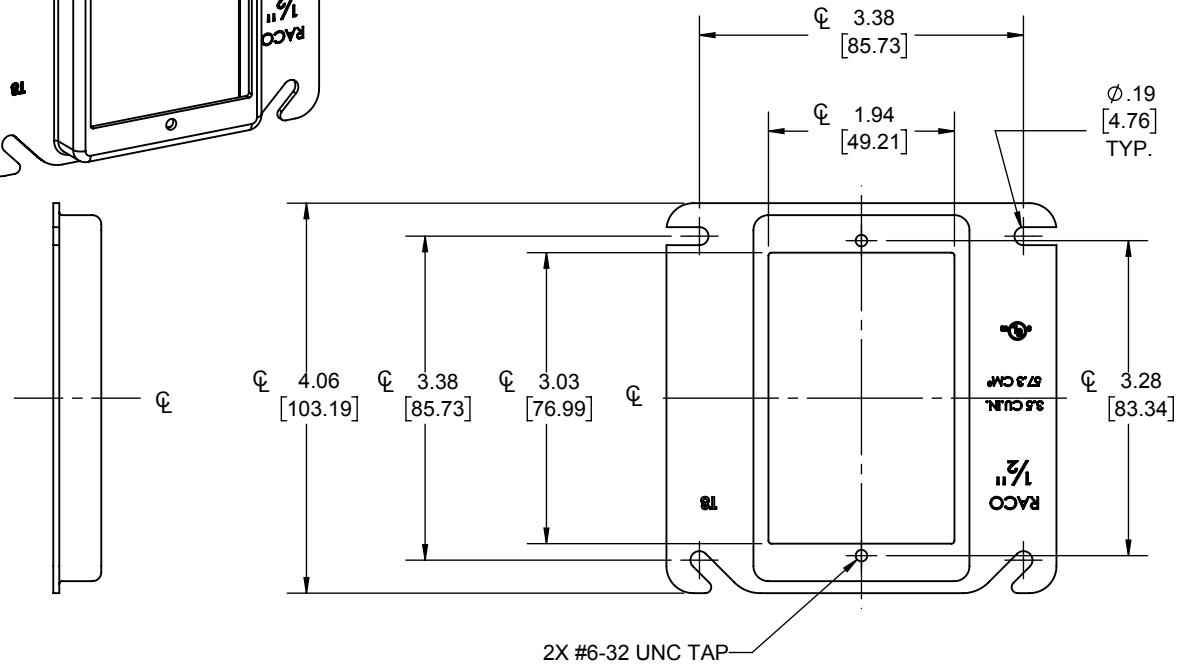
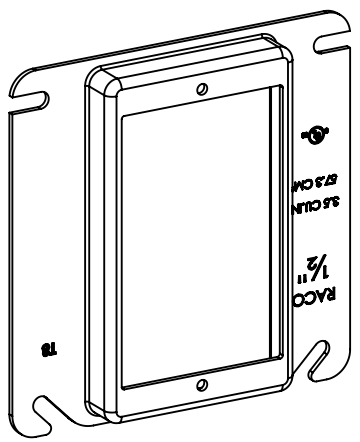

FASTENERS	STEEL	GALVANIZED
SIDE	STEEL	GALVANIZED
SPACER	STEEL	GALVANIZED
DESCRIPTION	MATERIAL	FINISH

LIST OF PARTS

THE DESIGN AND DIMENSIONS OF THE PRODUCT SHOWN ON THIS DRAWING ARE SUBJECT TO CHANGE WITHOUT NOTICE

TITLE:
COVER, 4" SQ. BOX, SINGLE DEVICE, RAISED 1/2"

- NOTES:
1. ALL DIMENSIONS ARE IN INCHES AND [MILLIMETERS]
 2. BOX VOLUME: 3.5 IN³ [57.3 CM³]
 3. cULus LISTED

TOLERANCE UNLESS OTHERWISE SPECIFIED



.XX DECIMAL ± .015
 .XXX DECIMAL ± .005
 ANGLE ± 2°

DRAWN BY:	RMV	SCALE:	SIZE:
APP. BY:	N.S.	1:2	A
DATE:	07-01-19		