

REVISIONS			
REV.	DATE	DESCRIPTION	BY
-	03-31-17	INITIAL RELEASE	RMV
1	12-14-20	UPDATED TO CURRENT STANDARDS	RMV

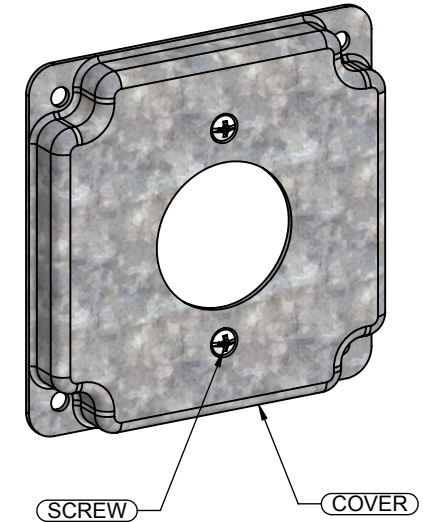
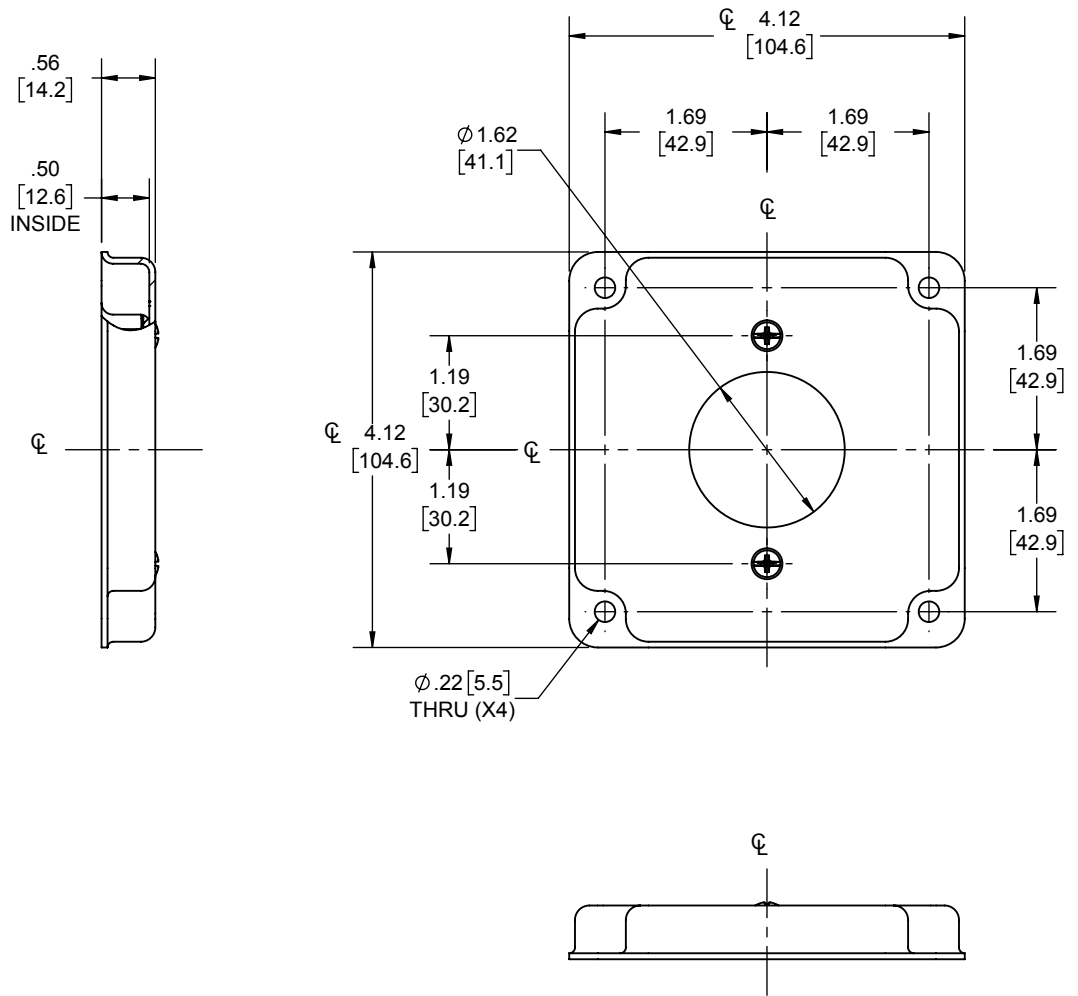

DESCRIPTION	MATERIAL	FINISH
SCREWS	STEEL	GALVANIZED
COVER	STEEL	GALVANIZED

LIST OF PARTS

THE DESIGN AND DIMENSIONS OF THE PRODUCT SHOWN ON THIS DRAWING ARE SUBJECT TO CHANGE WITHOUT NOTICE

TITLE:
**4" SQ CC COVER FOR (1) 20A
RECT 1.620"**

TOLERANCE UNLESS OTHERWISE SPECIFIED .XX DECIMAL ± .015 .XXX DECIMAL ± .005 ANGLE ± 2°			DRAWN BY:	RMV	SCALE:	SIZE:
			APP. BY:	RMV		
	DATE:	03-31-17	1:2	A		

- NOTES:
1. ALL DIMENSIONS ARE IN INCHES AND [MILLIMETERS]
 2. BOX VOLUME: 6.5 IN³ [107] CM³
 3. cULus LISTED