

REVISIONS			
REV.	DATE	DESCRIPTION	BY
-	11-02-22	INITIAL RELEASE	RMV

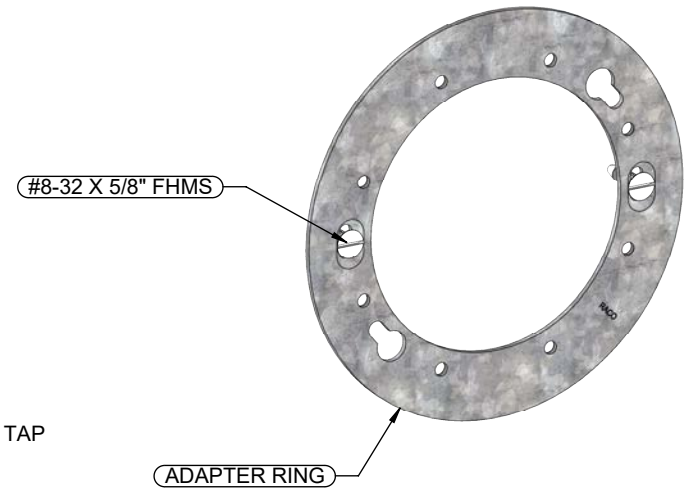
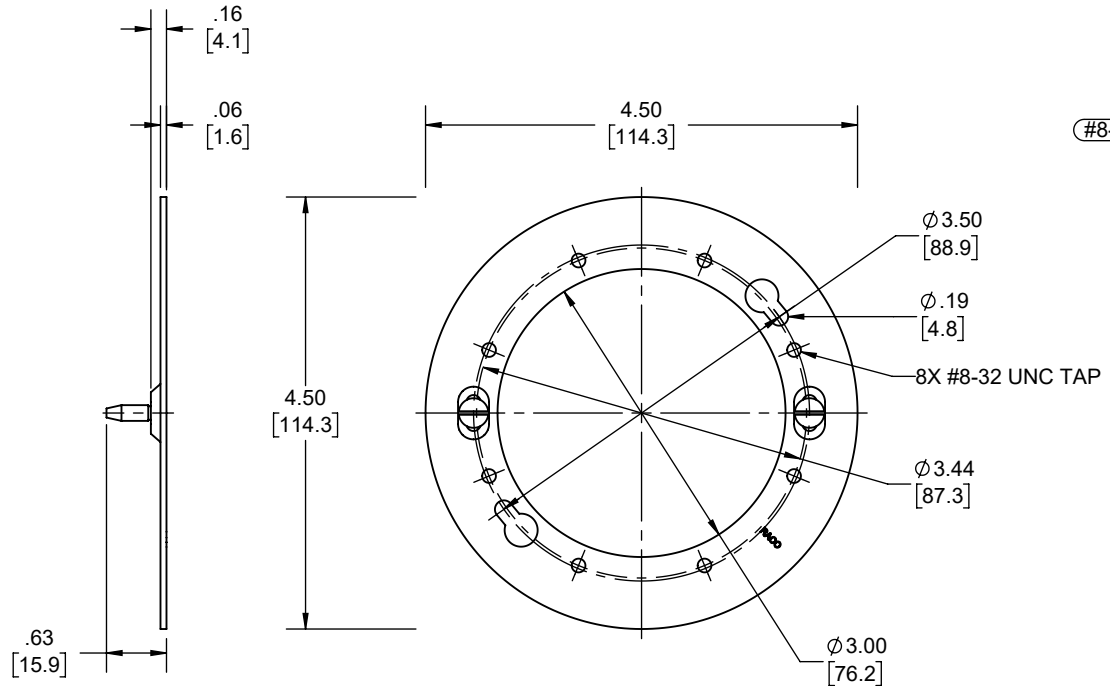

DESCRIPTION	MATERIAL	FINISH
FASTENERS	STEEL	GALVANIZED
ADAPTER RING	STEEL	GALVANIZED

**LIST OF PARTS**

THE DESIGN AND DIMENSIONS OF THE PRODUCT SHOWN ON THIS DRAWING ARE SUBJECT TO CHANGE WITHOUT NOTICE

TITLE:  
**CONCRETE ADAPTER RING**

TOLERANCE UNLESS OTHERWISE SPECIFIED  .XX DECIMAL ± .015 .XXX DECIMAL ± .005 ANGLE ± 2°			DRAWN BY:	RMV	SCALE:	SIZE:
			APP. BY:	N.S.		
	DATE:	11-02-22	1:2	A		

- NOTES:
1. ALL DIMENSIONS ARE IN INCHES AND [MILLIMETERS]
  2. VOLUME: 6.5 IN<sup>3</sup> [106.5 CM<sup>3</sup>]
  3. ACCEPTS SINGLE TOGGLE SWITCH AND SINGLE 1.406" RECEPTACLE