

REVISIONS			
REV.	DATE	DESCRIPTION	BY
-	05-03-24	INITIAL RELEASE	RMV

FILE NO.:
911-16 CUS

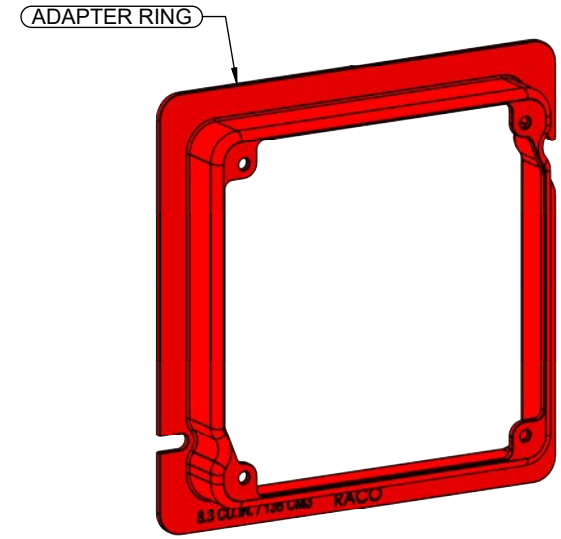
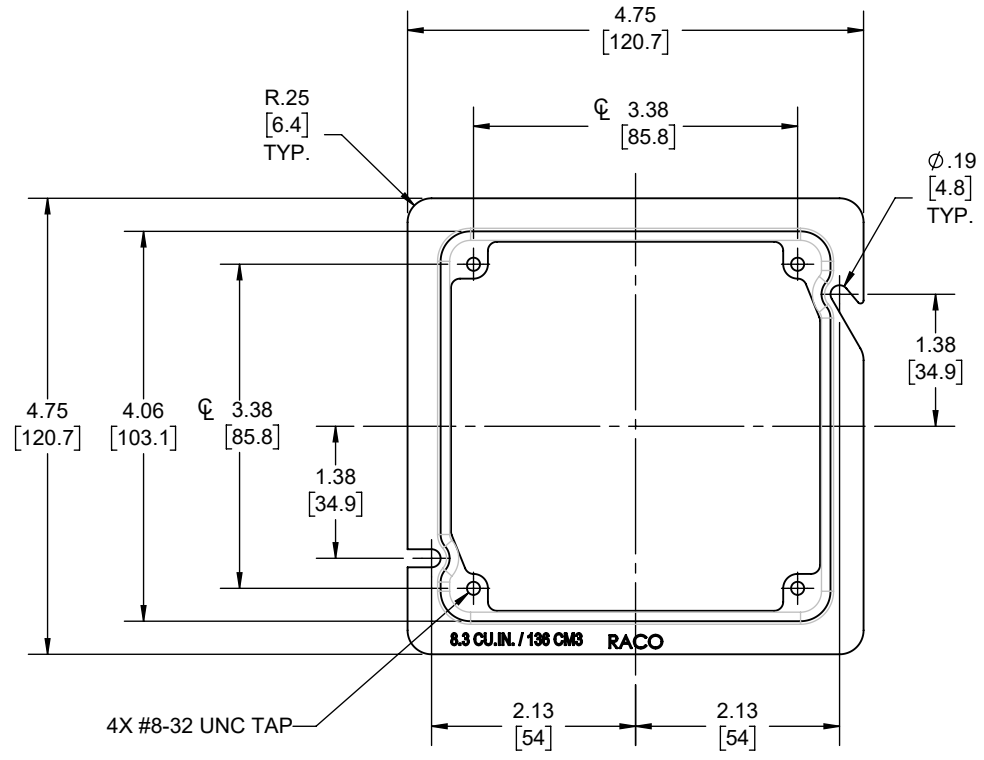

4X #8-32 UNC TAP

8.3 CU.IN. / 136 CM³ RACO

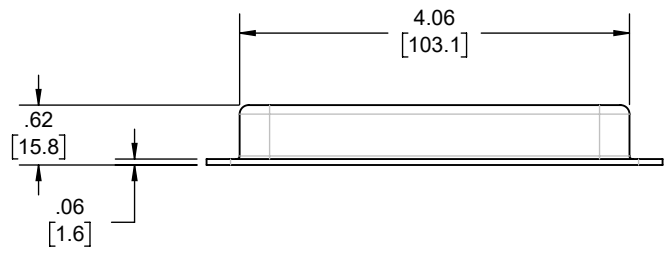

DIMENSION SHEET FOR CAT. NO.
911-16

ADAPTER RING	STEEL	GALVANIZED
DESCRIPTION	MATERIAL	FINISH

LIST OF PARTS

THE DESIGN AND DIMENSIONS OF THE PRODUCT SHOWN ON THIS DRAWING ARE SUBJECT TO CHANGE WITHOUT NOTICE

TITLE:
ADAPTER RING - RED

TOLERANCE UNLESS OTHERWISE SPECIFIED



.XX DECIMAL ± .015
.XXX DECIMAL ± .005
ANGLE ± 2°

DRAWN BY:	RMV	SCALE:	SIZE:
APP. BY:	N.S.	1:2	A
DATE:	05-03-24		

- NOTES:
1. ALL DIMENSIONS ARE IN INCHES AND [MILLIMETERS]
 2. VOLUME: 8.3 IN³ [136.0 CM³]
 3. cULus LISTED

8.5in*1in