

REVISIONS			
REV.	DATE	DESCRIPTION	BY
-	05-06-24	INITIAL RELEASE	RMV

FILE NO.: 911-17 CUS

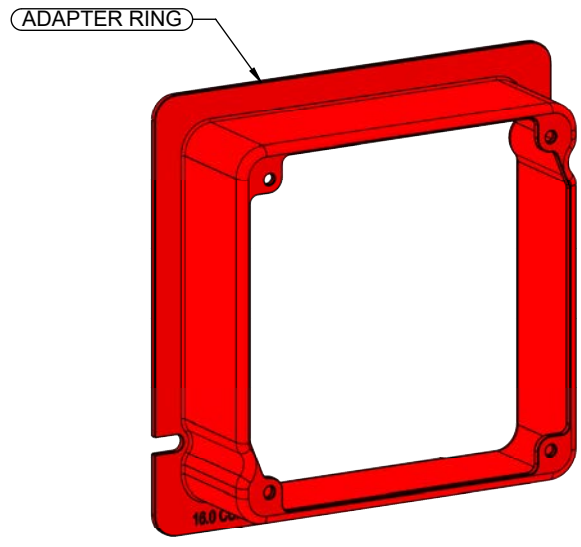
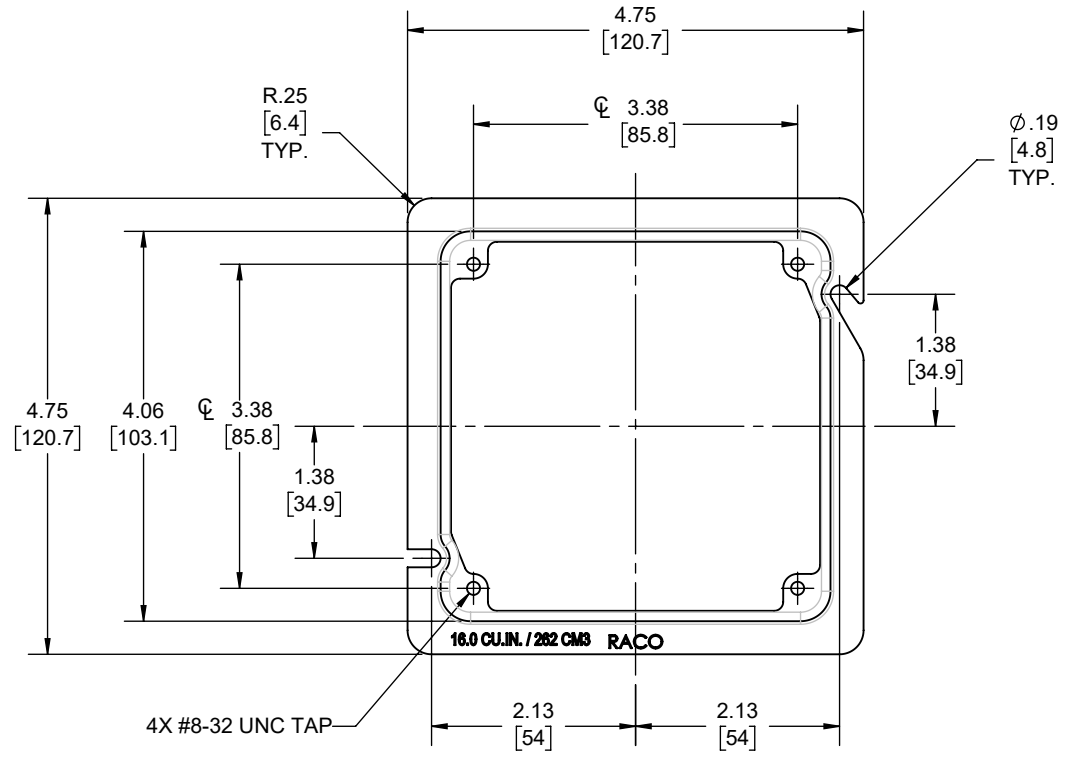

DIMENSION SHEET FOR CAT. NO. 911-17

ADAPTER RING	STEEL	GALVANIZED
DESCRIPTION	MATERIAL	FINISH

LIST OF PARTS

THE DESIGN AND DIMENSIONS OF THE PRODUCT SHOWN ON THIS DRAWING ARE SUBJECT TO CHANGE WITHOUT NOTICE

TITLE:
ADAPTER RING - RED

TOLERANCE UNLESS OTHERWISE SPECIFIED .XX DECIMAL ± .015 .XXX DECIMAL ± .005 ANGLE ± 2°			SCALE: 1:2	SIZE: A
	DRAWN BY:	RMV		
	APP. BY:	N.S.		
DATE:	05-06-24			

- NOTES:
- ALL DIMENSIONS ARE IN INCHES AND [MILLIMETERS]
 - VOLUME: 16.0 IN³ [262.2 CM³]
 - UL LISTED

8.5in*1in