

REVISIONS			
REV.	DATE	DESCRIPTION	BY
-	11-03-22	INITIAL RELEASE	RMV

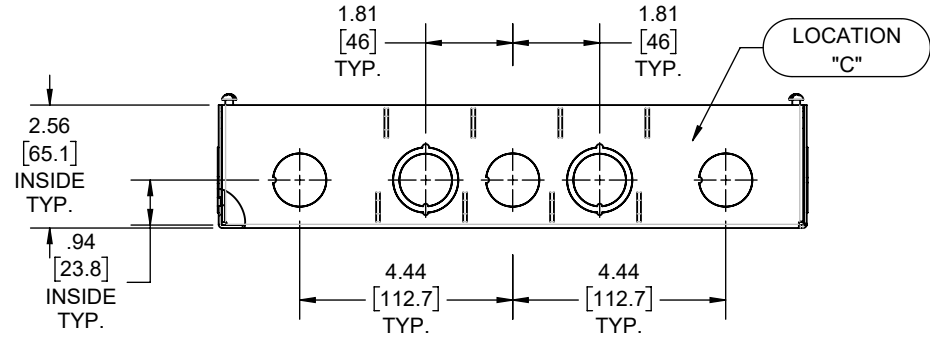
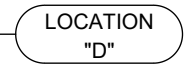
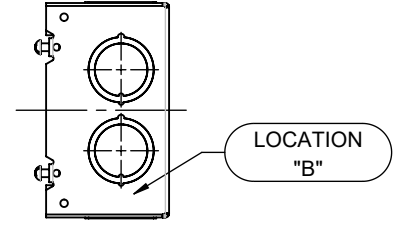
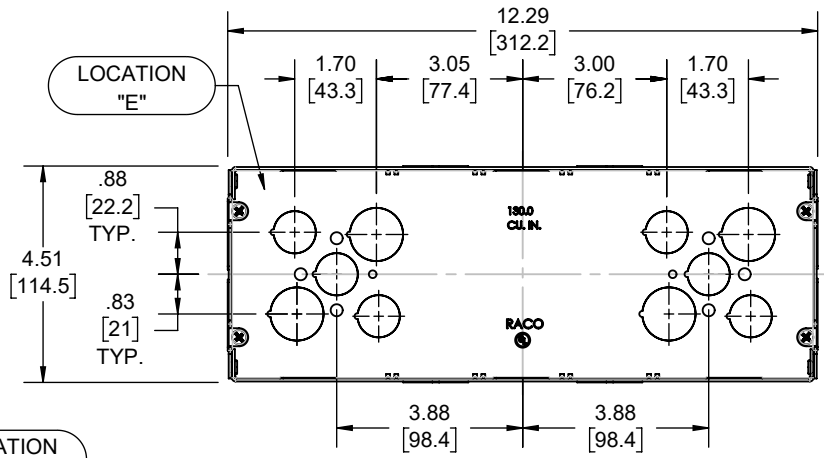
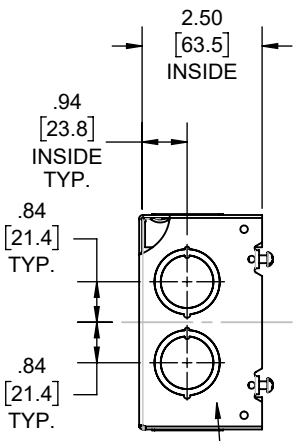
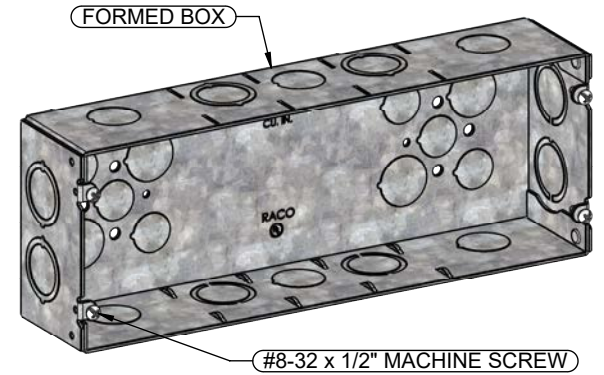
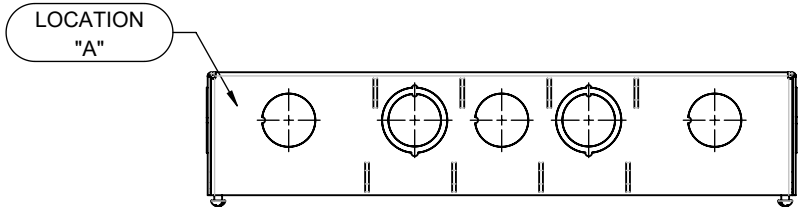

DESCRIPTION	MATERIAL	FINISH
FASTENERS	STEEL	GALVANIZED
FORMED BOX	STEEL	GALVANIZED

LIST OF PARTS

THE DESIGN AND DIMENSIONS OF THE PRODUCT SHOWN ON THIS DRAWING ARE SUBJECT TO CHANGE WITHOUT NOTICE

TITLE:
**5 GANG BOX W/ TOG-L-LOK,
2-1/2" DP.**

KNOCKOUTS		
TRADE SIZE	LOCATION	QTY.
1/2" KO	E	6
3/4" KO	E	4
3/4" KO	A, C	3
1/2"-3/4" CONCENTRIC KO	A, B, C, D	2

TOLERANCE UNLESS OTHERWISE SPECIFIED .XX DECIMAL ± .015 .XXX DECIMAL ± .005 ANGLE ± 2°			SCALE: 1:4
	DRAWN BY:	RMV	
	APP. BY:	N.S.	
DATE:		11-03-22	SIZE: A

- NOTES:
1. ALL DIMENSIONS ARE IN INCHES AND [MILLIMETERS]
 2. VOLUME: 130.0 IN³ [2130.3 CM³]
 3. UL LISTED