

REVISIONS			
REV.	DATE	DESCRIPTION	BY
-	02-15-22	INITIAL RELEASE	RMV

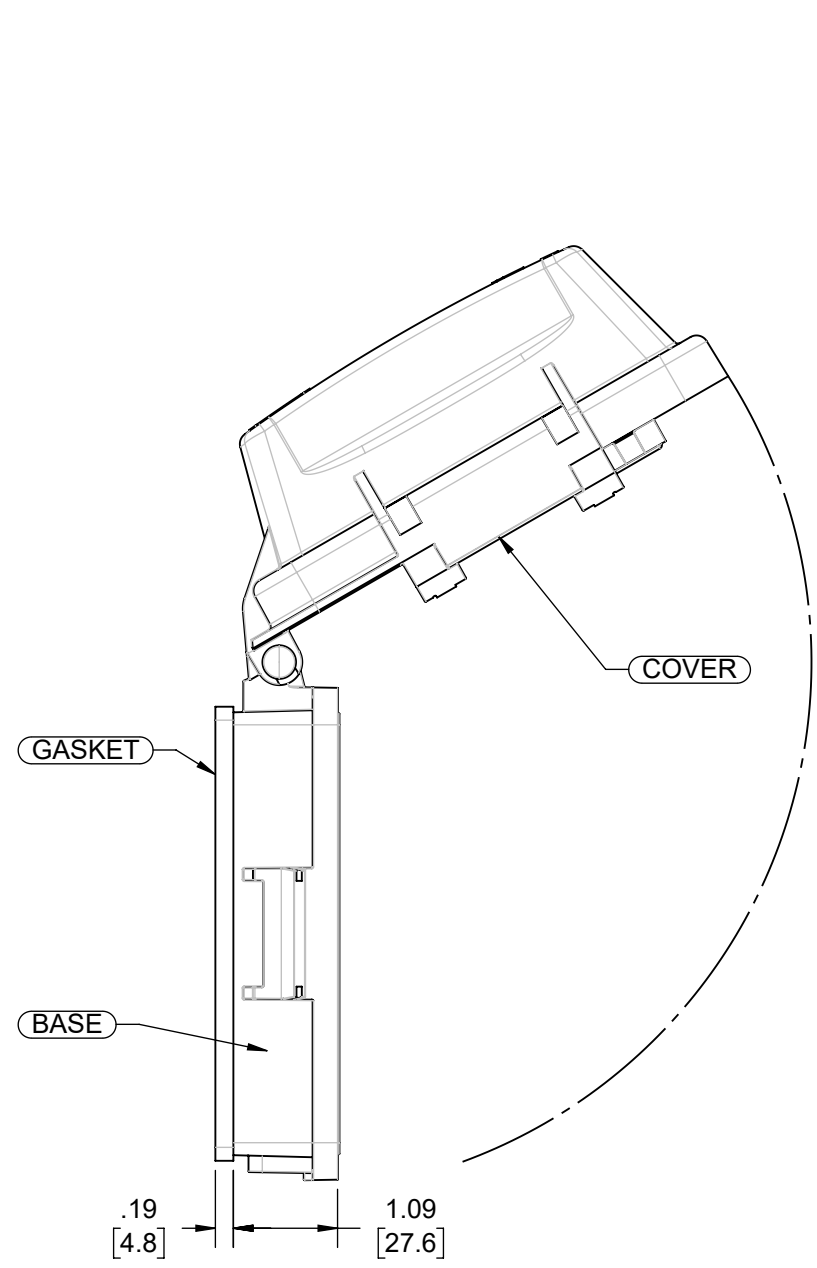

**SHOWN OPENED**  
**SCALE 1:2**

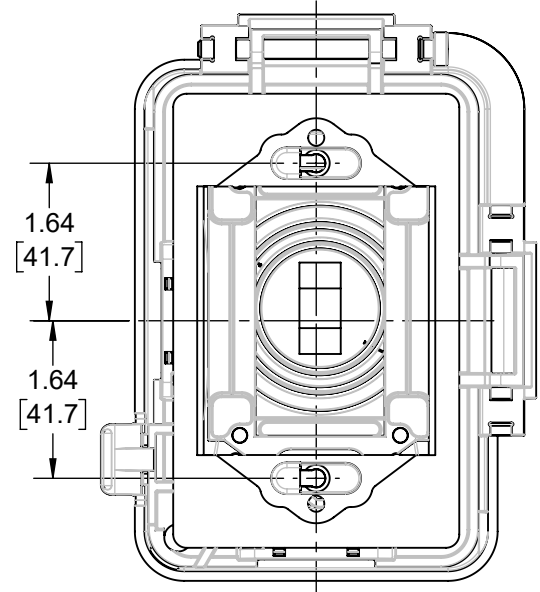
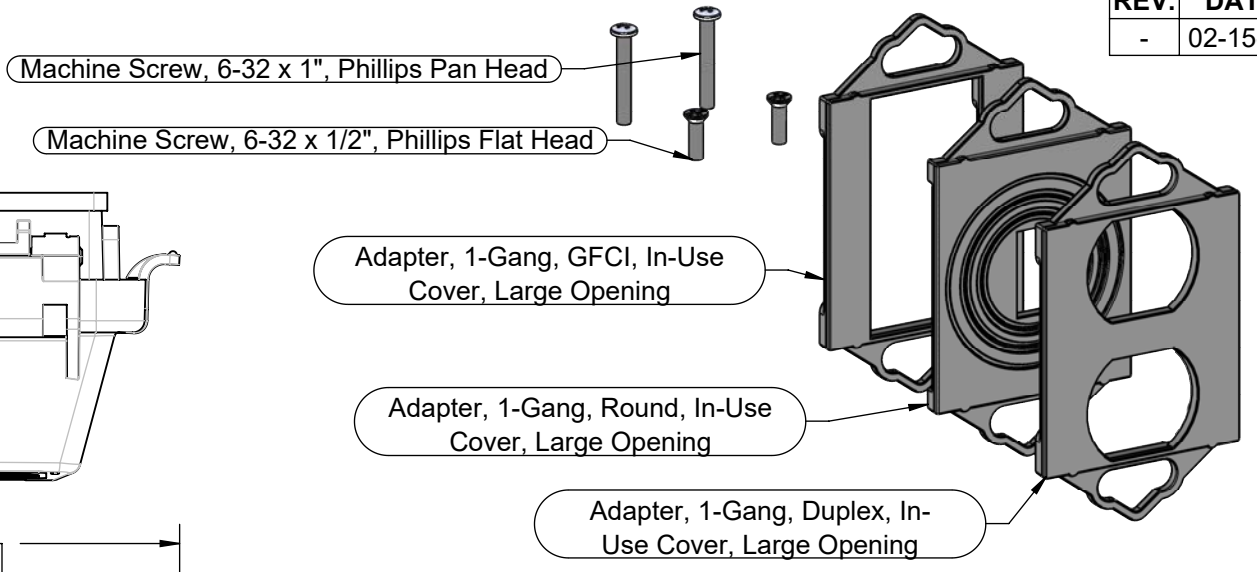
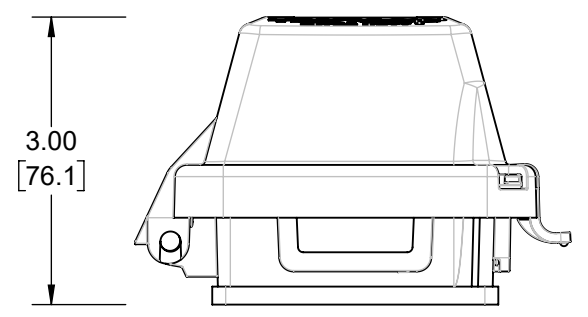
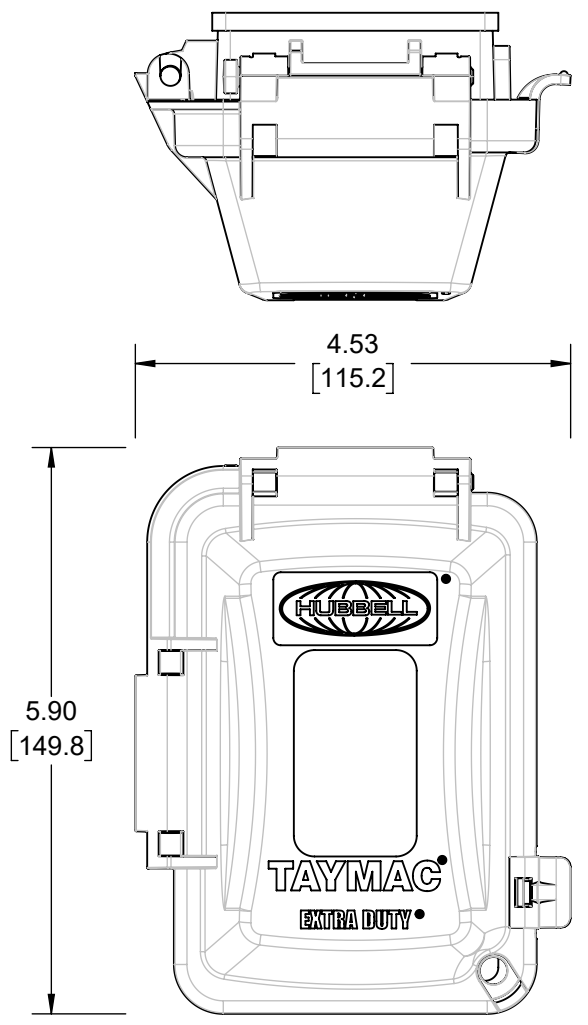

**REAR VIEW**  
**SCALE 1:2**



DESCRIPTION	MATERIAL	FINISH
FASTENERS	STEEL	GALVANIZED
GASKET	PE FOAM	N/A
ADAPTERS	PC	GRAY
COVER	PC	CLEAR
BASE	PC	GRAY

**LIST OF PARTS**

THE DESIGN AND DIMENSIONS OF THE PRODUCT SHOWN ON THIS DRAWING ARE SUBJECT TO CHANGE WITHOUT NOTICE

TITLE:  
**In-Use Enclosure, Clear Plastic, 1-Gang V/H, Extra Duty, Large Opening, w/o Window**

TOLERANCE UNLESS OTHERWISE SPECIFIED .XX DECIMAL ±.015 .XXX DECIMAL ±.005 ANGLE ±2°			SCALE: 1:2
	DRAWN BY:	RMV	
	APP. BY:	N.S.	
DATE:	02-15-22		

NOTES:  
1. ALL DIMENSIONS ARE IN INCHES AND [MILLIMETERS]  
2. UL LISTED