

REVISIONS			
REV.	DATE	DATE	BY
-	06-02-23	INITIAL RELEASE	RMV

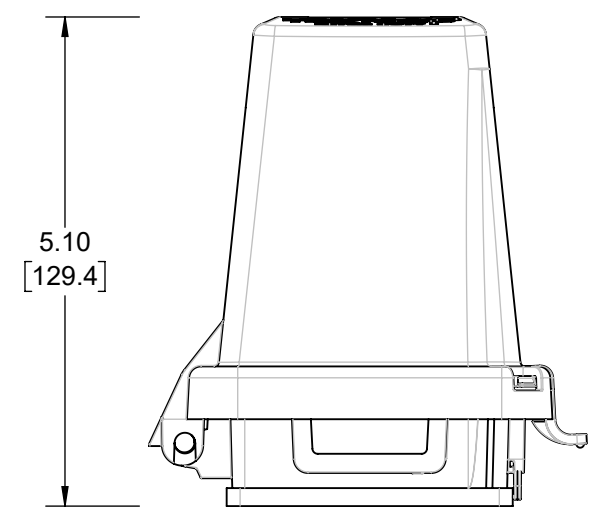
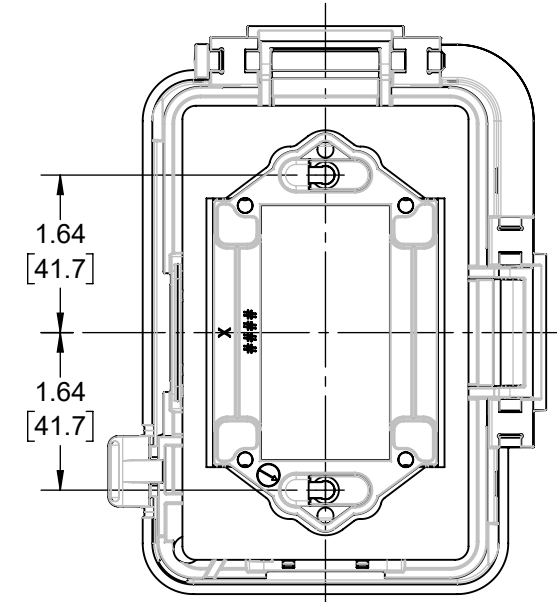
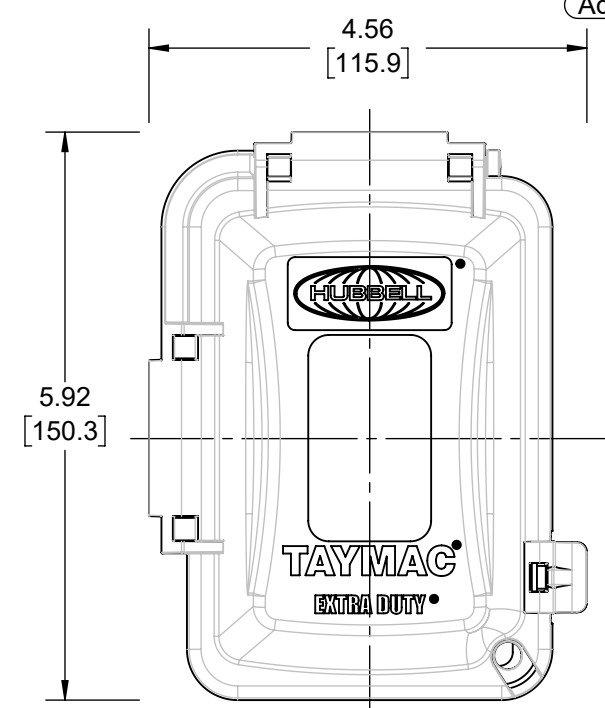
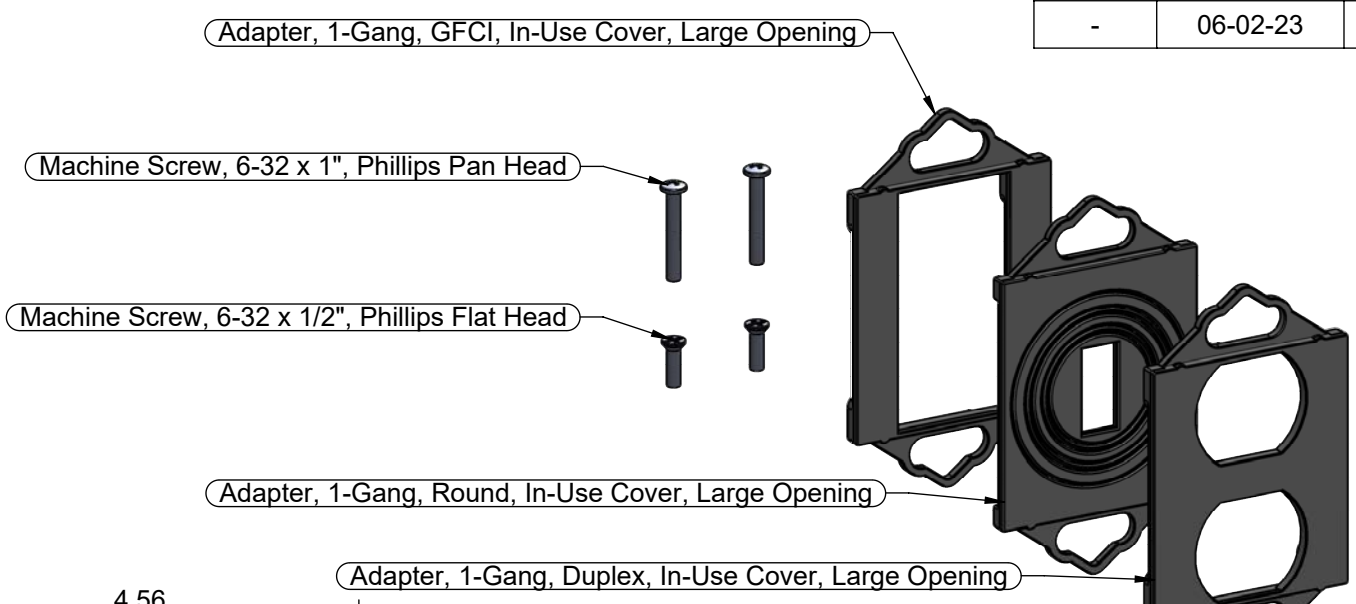
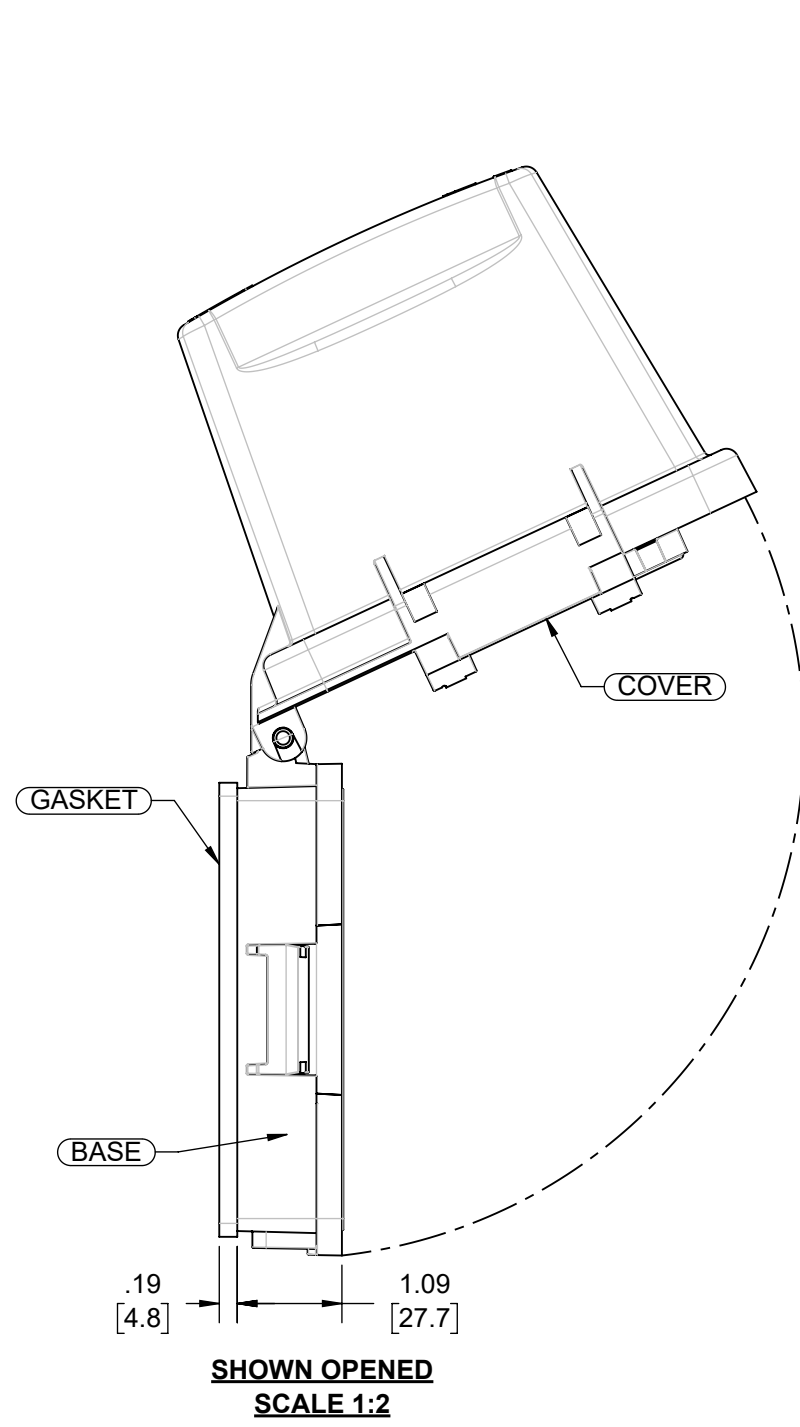

DESCRIPTION	MATERIAL	FINISH
FASTENERS	STEEL	GALVANIZED
GASKET	PE FOAM	-
ADAPTERS	PC	GRAY
COVER	PC	CLEAR
BASE	PC	GRAY

LIST OF PARTS

THE DESIGN AND DIMENSIONS OF THE PRODUCT SHOWN ON THIS DRAWING ARE SUBJECT TO CHANGE WITHOUT NOTICE

TITLE:
1-Gang Weatherproof In-Use Cover, EXTRA DUTY®, 16-in-1, 4-3/4 in. Deep, Clear

TOLERANCE UNLESS OTHERWISE SPECIFIED		
.XX DECIMAL ±.015	DRAWN BY: RMV	SCALE: 1:2
.XXX DECIMAL ±.005	APP. BY: N.S.	DATE: 06-02-23
ANGLE ±2°		

NOTES:
1. ALL DIMENSIONS ARE IN INCHES AND [MILLIMETERS]
2. UL LISTED