

REVISIONS			
REV.	DATE	DESCRIPTION	BY
-	04-11-22	INITIAL RELEASE	RMV

FILE NO.:
MX2150S CUS

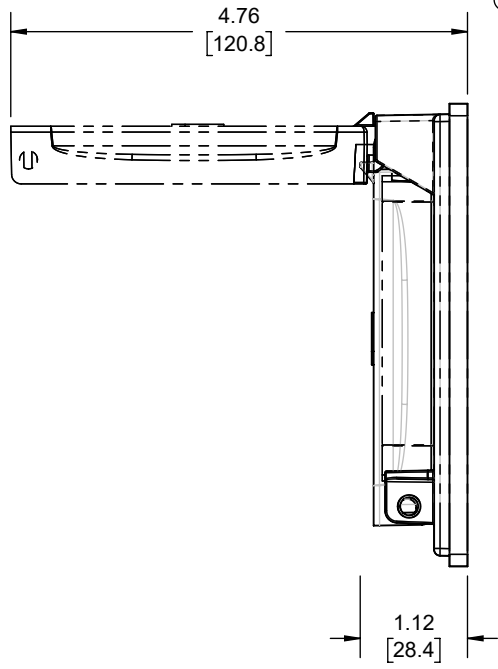
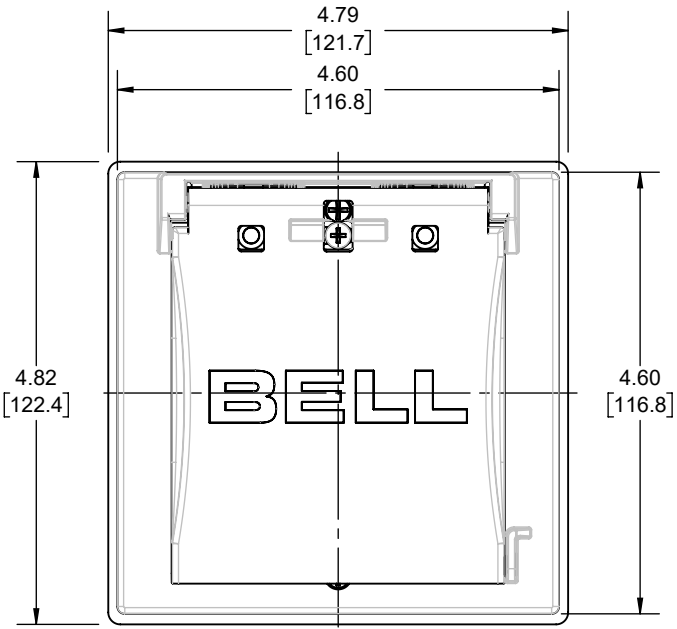
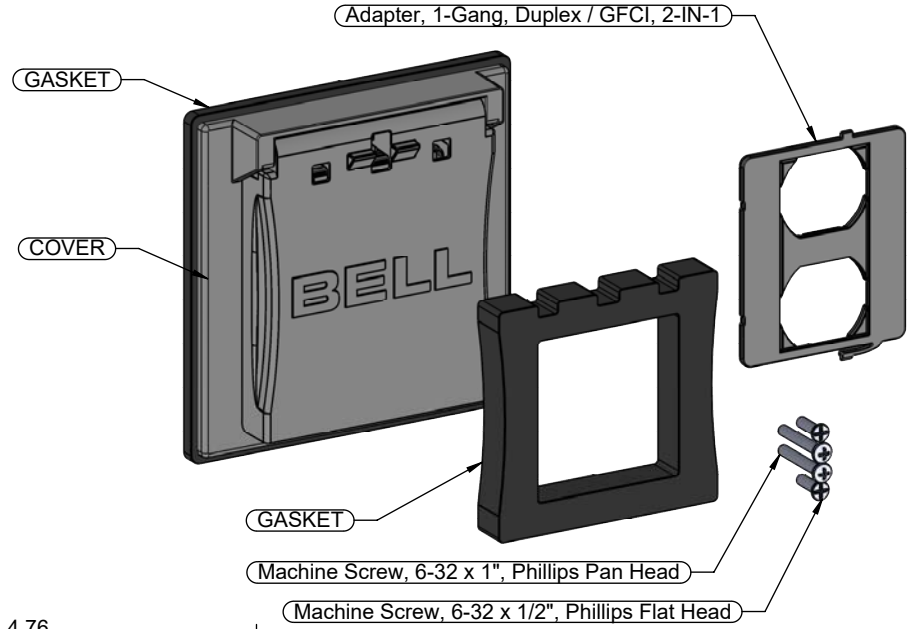
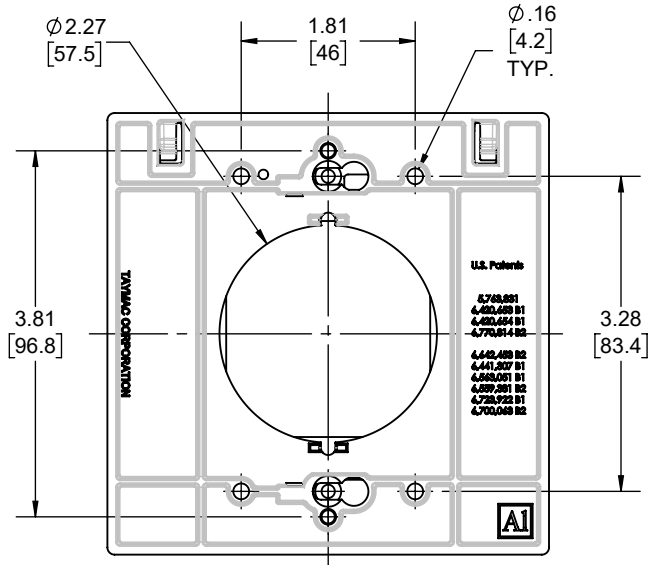

DESCRIPTION	MATERIAL	FINISH
ADAPTER PLATE	PC	GRAY
GASKET	PE FOAM	-
FASTENERS	STEEL	GALVANIZED
COVER	DIE CAST ALUMINUM	GRAY

LIST OF PARTS

THE DESIGN AND DIMENSIONS OF THE PRODUCT SHOWN ON THIS DRAWING ARE SUBJECT TO CHANGE WITHOUT NOTICE

TITLE:
2-GANG FLIP WEATHERPROOF COVER, V/H, 1-DEVICE, 3-IN-1, 2.25 DIA, GRAY

TOLERANCE UNLESS OTHERWISE SPECIFIED
.XX DECIMAL $\pm .015$
.XXX DECIMAL $\pm .005$
ANGLE $\pm 2^\circ$

	DRAWN BY:	RMV	SCALE:	SIZE:
	APP. BY:	N.S.		
	DATE:	04-11-22	1:2	A

- NOTES:
- ALL DIMENSIONS ARE IN INCHES AND [MILLIMETERS]
 - cULus LISTED

DIMENSION SHEET FOR CAT. NO.
MX2150S

8.5in*1in