

Ø11/16"
TYP.

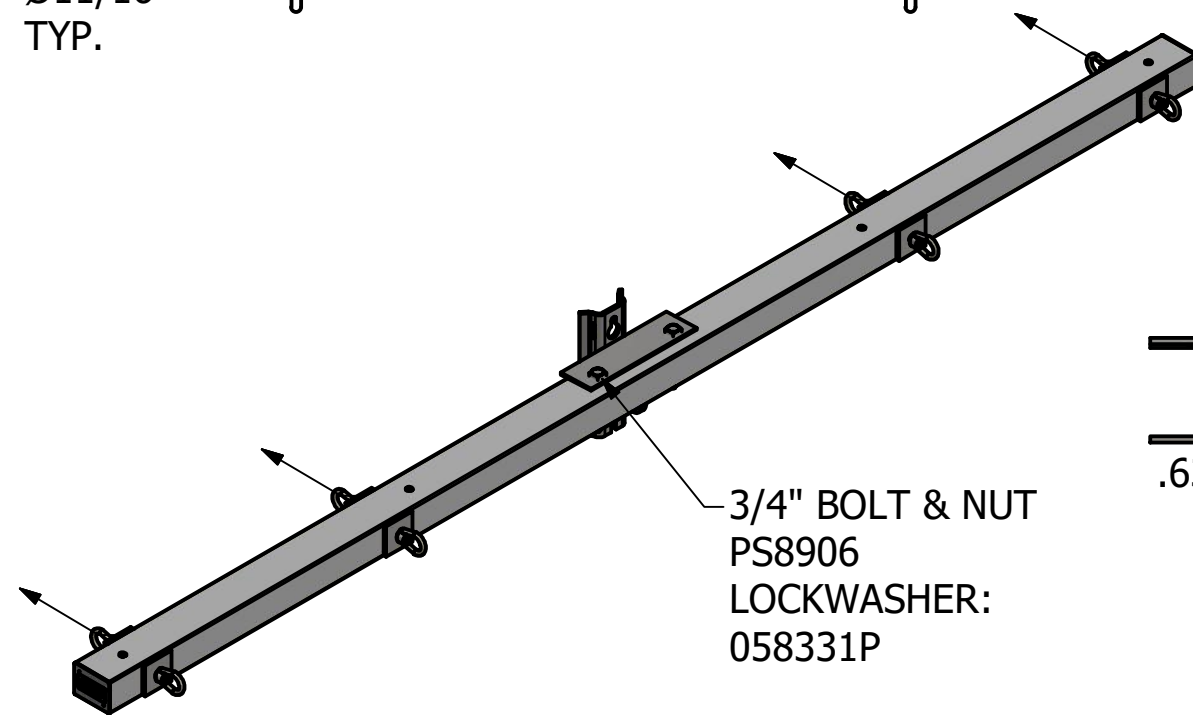

3/4" BOLT & NUT
PS8906
LOCKWASHER:
058331P

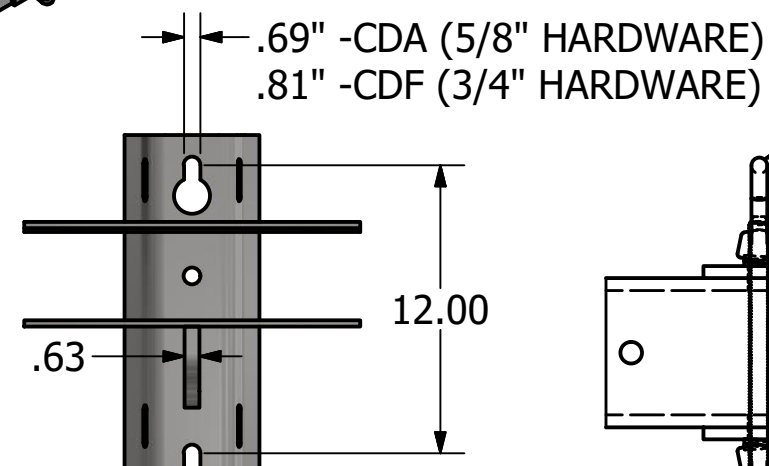

.69" -CDA (5/8" HARDWARE)
.81" -CDF (3/4" HARDWARE)

12.00

.63

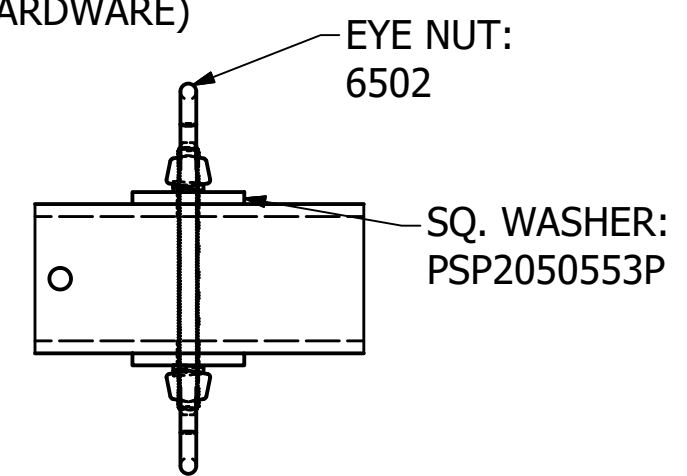

EYE NUT:
6502

SQ. WASHER:
PSP2050553P

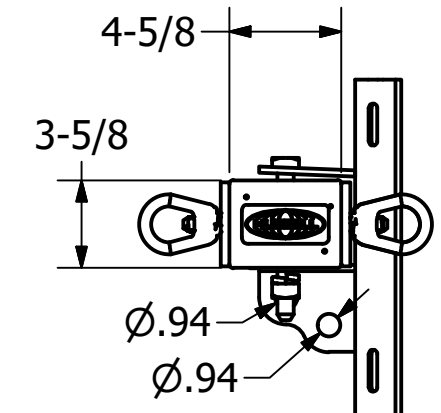

4-5/8

3-5/8

Ø.94

Ø.94

TABLE

CATALOG NO.	DESCRIPTION	" L "	" A "	" B "	" C "	" D "	MINIMUM ULTIMATE PER WIRE (lbs)	DEFLECTION PER 1,000 LBS/WIRE (in)	WEIGHT (lbs)
CDA25G060D2000	5 FT, 2 WIRE	60"	24"	N/A	26"	17"	10,000	0.17	50
CDA25G096D2000	8 FT, 2 WIRE	96"	42"	N/A	44"	17"	10,000	0.45	63
CDA25G096D4000	8 FT, 4 WIRE	96"	42"	15"	44"	17"	7,500	0.68	72
CDA25G120D2000	10 FT, 2 WIRE	120"	54"	N/A	56"	21"	7,500	0.82	71
CDA25G120D4000	10 FT, 4 WIRE	120"	54"	19"	56"	21"	6,000	1.10	80
CDA25G144D2000	12 FT, 2 WIRE	144"	66"	N/A	68"	N/A	6,000	1.46	80
CDA25G144D4000	12 FT, 4 WIRE	144"	66"	34"	68"	30"	4,200	1.92	89

FOR 3/4" CENTER MOUNTING HARDWARE, REPLACE 'A' WITH 'F'

CONSULT FACTORY FOR CUSTOM HOLE LOCATION REQUIREMENTS

- PAINTED WITH UV INHIBITOR PAINT.
- STANDARD COLOR GRAY (BROWN ALSO AVAILABLE).
- FOAM FILLED FIBERGLASS TUBE.
- SLEEVE OPTIONS AVAILABLE FOR ALL HOLES.
- RECOMMENDED HARDWARE TORQUE: 250 IN-LBS.

<h1>CHANCE®</h1>	HUBBELL POWER SYSTEMS, INC.				
	COMPOSITE CROSSARM 2500 SERIES DEADEND				
CONFIDENTIAL: THIS DRAWING AND ITS CONTENTS ARE CONFIDENTIAL AND THE EXCLUSIVE PROPERTY OF HUBBELL POWER SYSTEMS. NO PUBLICATION, DISTRIBUTION, OR COPIES MAY BE MADE WITHOUT THE WRITTEN CONSENT OF HUBBELL POWER SYSTEMS. HUBBELL POWER SYSTEMS UNPUBLISHED ALL RIGHTS RESERVED UNDER THE COPYRIGHT LAWS.	TITLE COMPOSITE CROSSARM 2500 SERIES DEADEND	SIZE B	CAT / PART / ASSY NO. SEE TABLE	DWG NO. SA-CDA25	REV C
DO NOT SCALE THIS DRAWING	DRN BY RAM	DATE 4/19/18	SHEET 1 OF 1		