

CATALOG NUMBER	CABLE RUN - A (kcmil)				CABLE TAP - AA (kcmil)				DIMENSIONS IN INCHES				
	ACSR		COPPER OR ALUM.		ACSR		COPPER OR ALUM.		H	J	L	T	W
	MIN.	MAX.	MIN.	MAX.	MIN.	MAX.	MIN.	MAX.					
UP34R	110.8 (.481)	397.5 (.743)	3/0 STR. (.464)	400 (.728)	110.8 (.481)	397.5 (.743)	3/0 STR. (.464)	400 (.728)	4.62 [117]	1/2 - 13	4.00 [102]	.44 [11]	2.62 [67]
UP45R36R	336.4 (.741)	.795 (1.140)	397.5 (.724)	954 (1.124)	110.8 (.481)	477 (.814)	3/0 STR. (.464)	500 (.813)	5.28 [134]	1/2 - 13	4.00 [102]	.53 [13]	2.88 [73]
UP45R	336.4 (.741)	.795 (1.140)	397.5 (.724)	954 (1.124)	336.4 (.741)	795 (1.140)	397.5 (.724)	954 (1.124)	6.25 [159]	5/8 - 16	4.50 [114]	.59 [15]	3.25 [83]

REV	DATE	DESCRIPTION	ECO	BY	C'H'K.
A	03/18/2016	REDRAW TO INVENTOR	43267	LM	MB

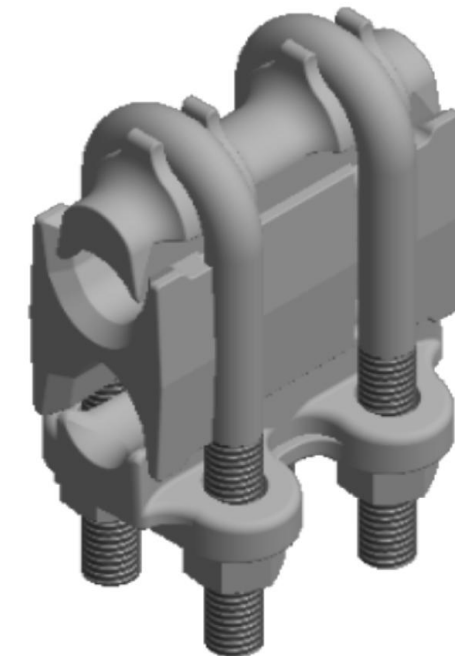
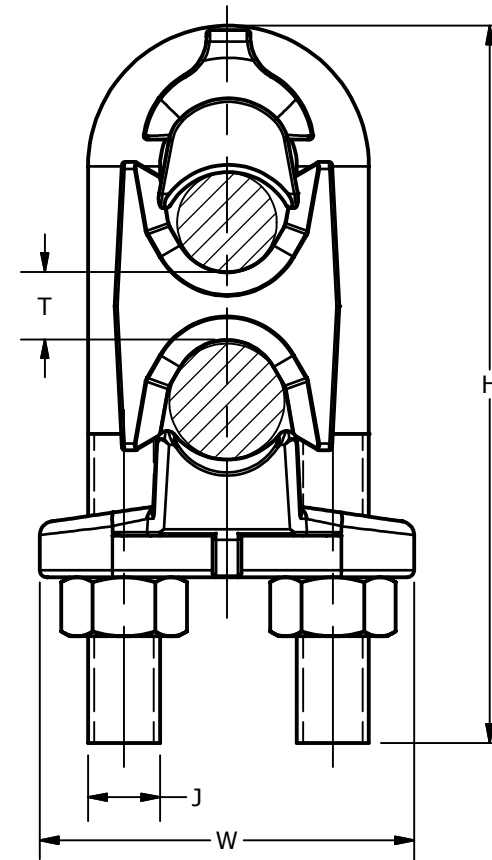
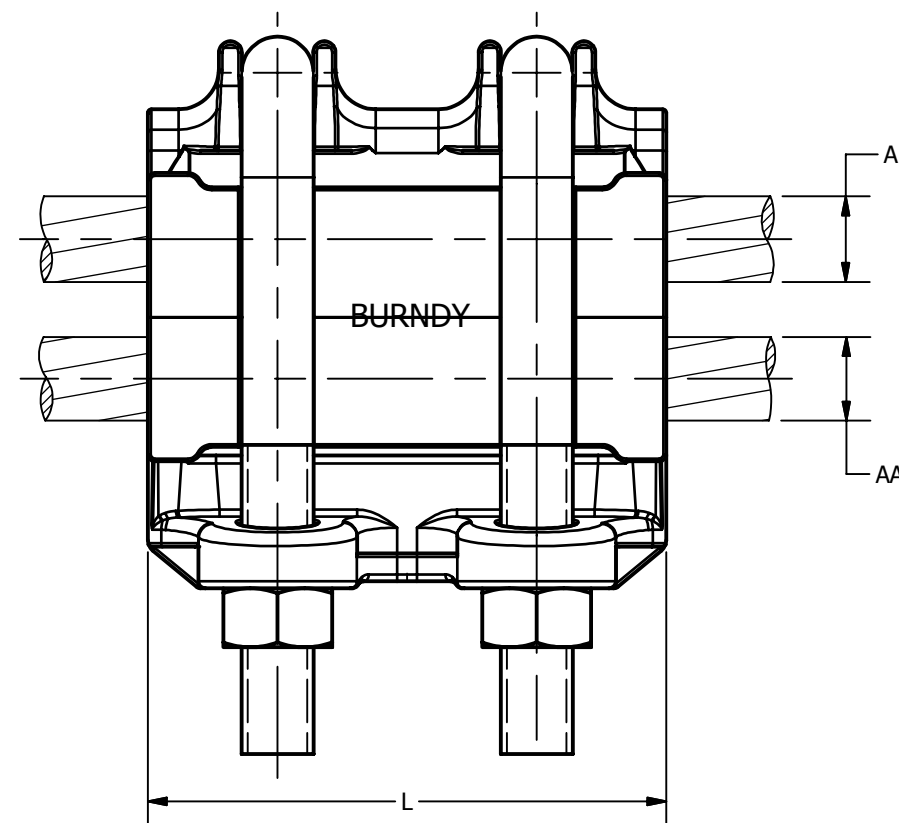

NOTES:

1. A HEAVY DUTY PARALLEL CLAMP WHICH ACCOMMODATES A BROAD RANGE OF ALUMINUM, ACSR AND COPPER CONDUCTORS. SADDLE, SPACER AND BOTTOM CAP ARE ALUMINUM ALLOY CASTINGS, HEAT TREATED TO WITHSTAND THE CLAMPING FORCE EXERTED BY THE ALUMINUM ALLOY U-BOLTS. CONTACT SURFACES ARE FACTORY CLEANED TO REMOVE OXIDE FILM AND FACTORY COATED TO PREVENT RE-FORMATION OF THE FILM. U-BOLTS ARE CAPTURED IN THE SADDLE TO SIMPLIFY INSTALLATION AND ALL GROOVE MOUTHS ARE GENEROUSLY BELLED TO PREVENT CABLE DAMAGE.
2. ANY COMBINATION OF ALUMINUM, ACSR OR COPPER CABLES WITHIN THE SPECIFIED RANGES OF EACH INDIVIDUAL CONNECTOR MAY BE PHYSICALLY ACCOMODATED. HOWEVER, WHEN THE CONNECTOR IS INSTALLED ON THE MAXIMUM ALUMINUM, ACSR OR COPPER CONDUCTOR ACCOMODATED BY GROOVE A, THE LARGEST RECOMMENDED TAP CONDUCTOR IS THE MAXIMUM SIZE ALUMINUM OR ACSR ACCOMODATED BY GROOVE AA, OR THE COPPER CONDUCTOR SIZE WHICH IS THE CURRENT CARRYING EQUIVALENT TO THE MAXIMUM ALUMINUM OR ACSR, ACCOMODATED BY GROOVE AA.
3. DIMENSIONS IN BRACKETS [] ARE IN MILLIMETERS ROUNDED OFF TO THE NEAREST MILLIMETER, UNLESS OTHERWISE SPECIFIED AND ARE FOR REFERENCE ONLY.

TO ORDER BURNDY® PRODUCTS CALL		PARALLEL CLAMP	
UNITED STATES 1-800-346-4175 (LONDONDERRY, NH)		ITEM NO: N/A	
CANADA: 1-800-361-6975 (QUEBEC) 1-800-387-6487 (ALL OTHER PROVINCES)		CAT. NO: UP - R	
FOR PRODUCT INFO: http://www.burndy.com		DRAWN BY: LOKESH M 3/18/2016	
		CHECKER: MANIKANDAN B 3/21/2016	
		DSN APRVL: W ZAHLMAN 3/22/2016	
		MFG APRVL: --	
		QA APRVL: C KOWALCZYK 3/22/2016	
		MKT APRVL: J HALL 3/22/2016	
		PROD FAM: --	
		DRAWING NO	
		PROJECT #: --	
		SIZE	
		DOCUMENT TYPE: SALES	
		REL LEVEL: Released	
		SA038235-01	
		SHEET 1 OF 1	
		REV	
		A	