

RS3500.300

HSS 3 INCH SCH 80
 TORQUE: 13,000 FT-LBS
 TENSION/ COMPRESSION*: 91 KIP
 COUPLING ULTIMATE TENSION: 120 KIP
 *BASED ON A $K_t = 7 \text{ FT}^{-1}$

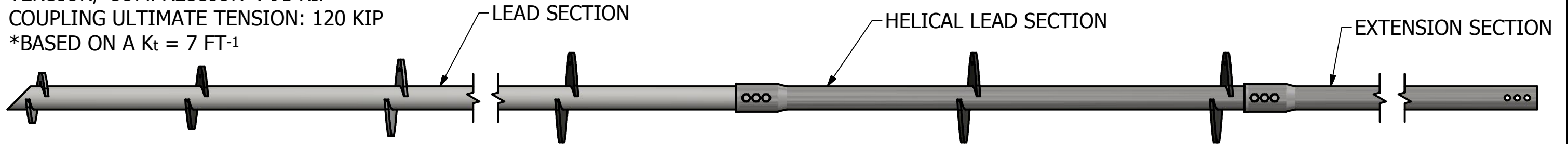

** NOTES **

- HOT DIP GALVANIZED PER ASTM A123
- LEAD AND EXTENSION SECTION LENGTHS AND HELIX SPACINGS ARE NOMINAL
- PIPE SHAFT MATERIAL PER ASTM A618 OR A500 GRADE B/C MIN YIELD 50KSI.
- HELIX MATERIAL LOW CARBON STEEL MEETING THE GENERAL REQUIREMENTS OF AISI OR ASTM A572, A656, OR A1018
- COUPLING BOLTS: 0.75" DIAMETER X 5-1/4" LONG HEX HEAD PER SAE J425 GRADE 5
- MANUFACTURER TO HAVE IN EFFECT INDUSTRY RECOGNIZED WRITTEN QUALITY CONTROL FOR ALL MATERIALS AND MANUFACTURING PROCESSES
- ALL WELDING TO BE DONE BY WELDERS CERTIFIED UNDER SECTION 5 OF THE AWS CODE D1.1.
- ALL MEASUREMENTS ARE IN INCHES UNLESS SPECIFIED.
- HARDWARE IS PROVIDED WITH EXTENSIONS AND HELICAL EXTENSION SECTIONS.
- HELIX SPACING IT THREE DIAMETERS OF LOWER HELIX.

LEAD SECTION HELICAL EXTENSION SECTION EXTENSION SECTION

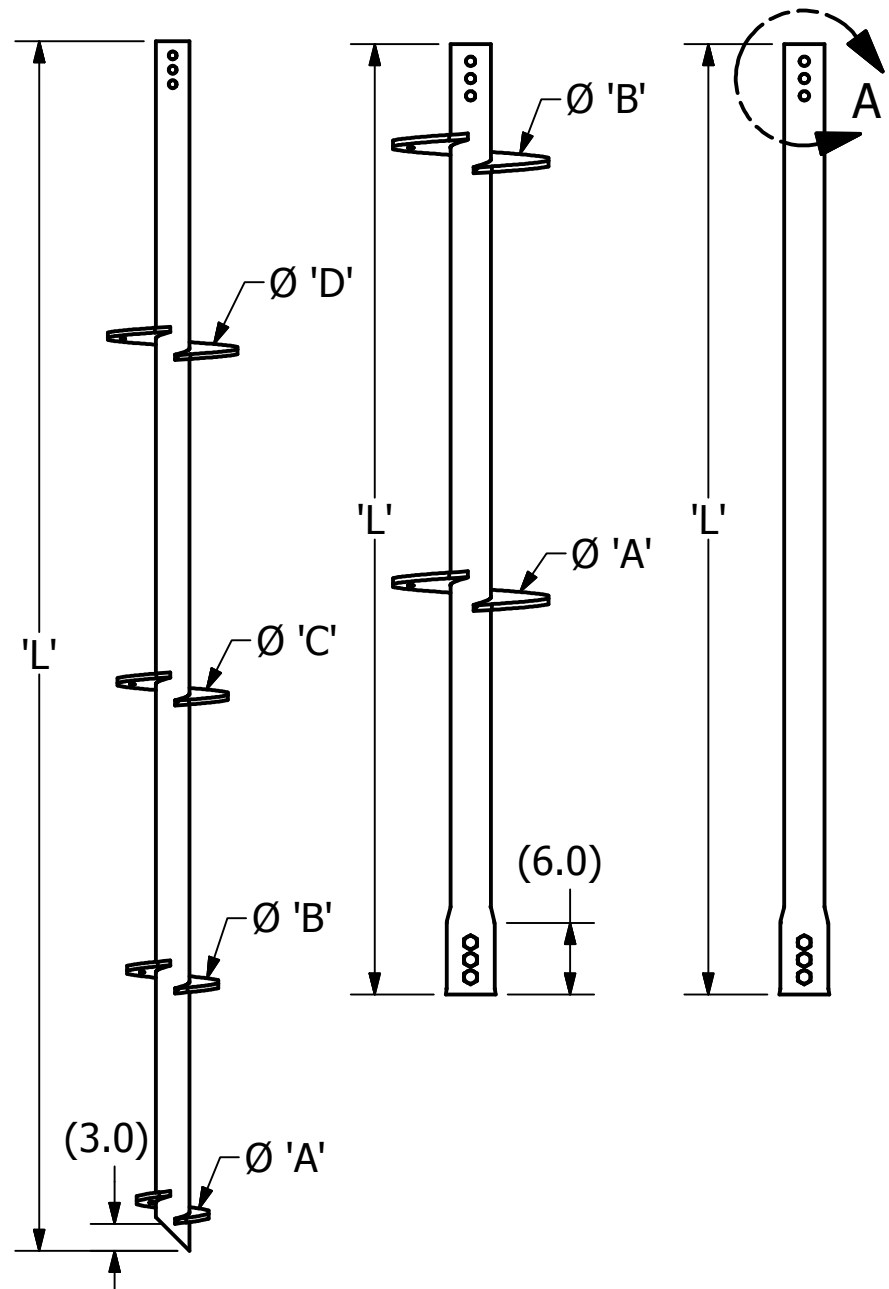

CATALOG NUM	DESCRIPTION	'A'	'B'	'C'	'D'	'L' (FT)
C1070560	LEAD, RS3500.300, 8/10 X 3.5FT	8	10	-	-	3.5
C1070563	LEAD, RS3500.300, 8/10/12 X 7FT	8	10	12	-	7
C1070566	LEAD, RS3500.300, 8/10/12/14 X 10FT	8	10	12	14	10
T1070813	LEAD, RS3500.300, 10 X 7FT	10	-	-	-	7
C1070561	LEAD, RS3500.300, 10/12 X 4FT	10	12	-	-	4
C1500023	LEAD, RS3500.300, 10/12 X 7FT	10	12	-	-	7
T1070812	LEAD, RS3500.300, 10/12 X 10FT	10	12	-	-	10
C1070564	LEAD, RS3500.300, 10/12/14 X 7FT	10	12	14	-	7
C1070567	LEAD, RS3500.300, 10/12/14/14 X 10FT	10	12	14	14	10
C1070565	LEAD, RS3500.300, 12/14/14 X 10FT	12	14	14	-	10
C1070568	LEAD, RS3500.300, 12/14/14/14 X 10FT	12	14	14	14	10
C1070573CU	EXTENSION, RS3500.300, 3.5FT	-	-	-	-	3.5
C1500025CU	EXTENSION, RS3500.300, 5FT	-	-	-	-	5
C1500026CU	EXTENSION, RS3500.300, 7FT	-	-	-	-	7
C1500216CU	EXTENSION, RS3500.300, 10FT	-	-	-	-	10
C1070577CU	EXTENSION, RS3500.300, 14 X 5FT	14	-	-	-	5
C1070579CU	EXTENSION, RS3500.300, 14/14 X 7FT	14	14	-	-	7
P1100814P	BOLT, HH .75 X 5.25	-	-	-	-	-
450315P	NUT, FINISHED HH .750-10 GLAV	-	-	-	-	-
058331P	WASHER, LOCK SPR .750 GALV	-	-	-	-	-

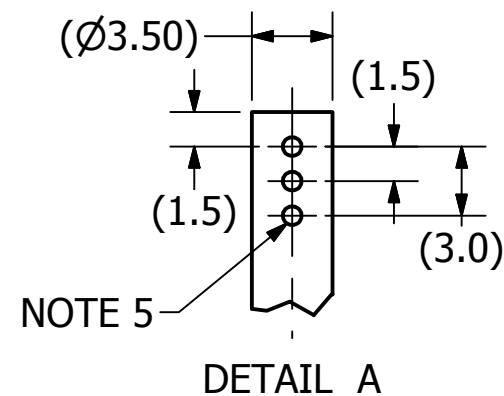

<h2>CHANCE®</h2> <p>CONFIDENTIAL: THIS DRAWING AND ITS CONTENTS ARE CONFIDENTIAL AND THE EXCLUSIVE PROPERTY OF HUBBELL POWER SYSTEMS. NO PUBLICATION, DISTRIBUTION, OR COPIES MAY BE MADE WITHOUT THE WRITTEN CONSENT OF HUBBELL POWER SYSTEMS. HUBBELL POWER SYSTEMS UNPUBLISHED ALL RIGHTS RESERVED UNDER THE COPYRIGHT LAWS.</p>		HUBBELL POWER SYSTEMS, INC.		
	HELICAL PIER RS3500.300			
SIZE B	CAT / PART / ASSY NO. SEE CHART	DWG NO. SA1070573CU	REV B	
DO NOT SCALE THIS DRAWING	DRN BY TLB	DATE 3/29/19	SHEET 1 OF 1	