

# RS5500.361 HIGH CAPACITY HELICAL PILES

## --NOTES--

1. FINISH: HOT DIP GALVANIZED PER ASTM A123. ALSO AVAILABLE IN BLACK (NON-GALVANIZED) FINISH. ADD "NG" TO THE OF THE CATALOG NUMBER FOR NON-GALVANIZED PRODUCT.
2. MATERIAL: HIGH STRENGTH STEEL. BOLT HARDWARE IS SAE J429 GRADE 5 STEEL OR EQUIVALENT.
3. MANUFACTURER TO HAVE IN EFFECT INDUSTRY RECOGNIZED WRITTEN QUALITY CONTROL FOR ALL MATERIALS AND MANUFACTURING PROCESSES.
4. ALL WELDING TO BE DONE BY CERTIFIED WELDERS UNDER SECTION 4 OF THE AWS CODE D1.1
5. HARDWARE IS PROVIDED WITH EXTENSIONS AND CAP- Ø1-1/4, HEX HEAD, 3 PLACES.
6. HELIX SPACING IN LEADS IS EQUAL TO THREE DIAMETERS OF LOWER HELIX. LENGTH "L" IS NOMINAL.

CATALOG NUMBER	DESCRIPTION	"L" LENGTH
C1073150	LEAD, RS5500.361 16 X 10 FT, HCP	120
C1073155	LEAD, RS5500.361 12/14 X 10 FT, HCP	120
C1073156	LEAD, RS5500.361 14/14 X 10 FT, HCP	120
C1073157	LEAD, RS5500.361 16/16 X 10 FT, HCP	120
C1073158	LEAD, RS5500.361 16/18 X 10 FT, HCP	120
C1073159	EXTENSION, RS5500.361 3.5 FT SC, HCP	42
C1073160	EXTENSION, RS5500.361 5 FT SC, HCP	60
C1073161	EXTENSION, RS5500.361 7 FT SC, HCP	84
C1073162	EXTENSION, RS5500.361 10 FT SC, HCP	120
C1073163	EXTENSION, RS5500.361 15 FT SC, HCP	180
C1073164	EXTENSION, RS5500.361 21 FT SC, HCP	252
C1073165	CAP, NEW CONSTRUCTION, RS5500.361 SC, HCP, TENS/COMP	N/A
C1073166	CAP, NEW CONSTRUCTION, RS5500.361 SC, HCP, COMP ONLY	N/A
C1073167	LEAD, RS5500.361 12/14/16 X 10 FT, HCP	120
C1073173	LEAD, RS5500.361 14 X 10FT, HCP	120
C1073174	LEAD, RS5500.361 14/16/18 X 10FT, HCP	120
C1073175	EXTENSION, W/ HELIX, RS5500.361 16 X 5FT SC, HCP	60
C1073176	EXTENSION, W/ HELIX, RS5500.361 18 X 5FT SC, HCP	60
C1073185	EXTENSION, W/ HELIX, RS5500.361 20/22 X 10FT 6SC, HCP	120
C1073186	EXTENSION, W/ HELIX, RS5500.361 24 X 6FT 6SC, HCP	72

TORQUE RATING: 56,000 FT-LB

ULTIMATE TENSION/COMPRESSION CAPACITY: 280 KIP\*

\*BASED ON A TORQUE FACTOR (KT) FOR PIPE PILE OF 5.0

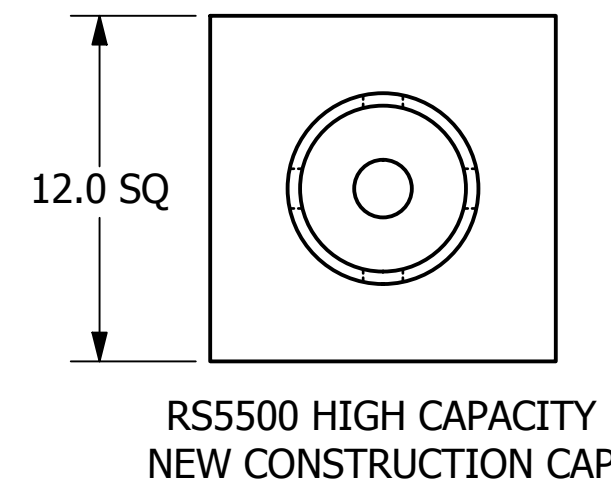
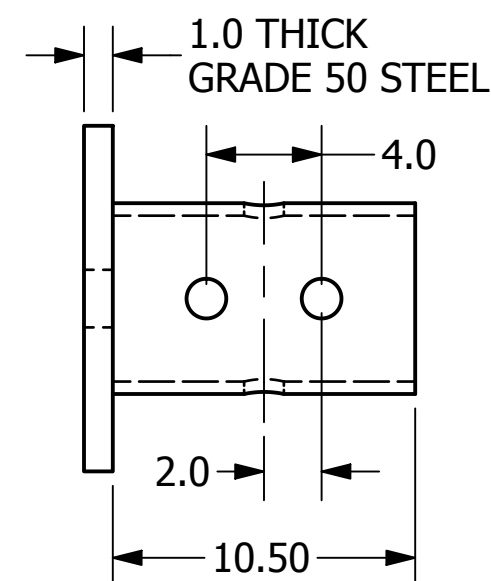
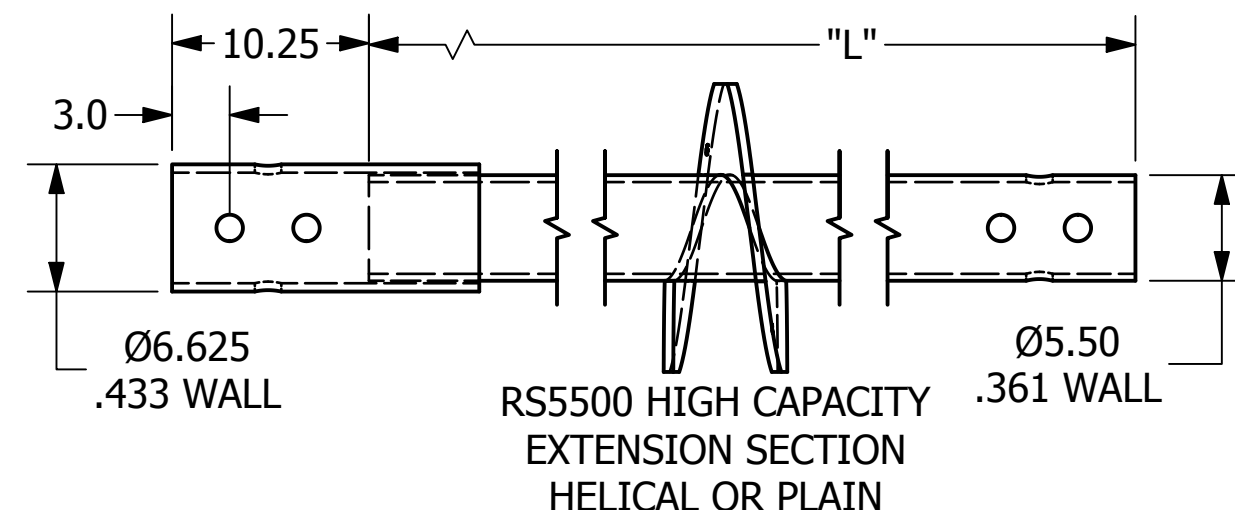
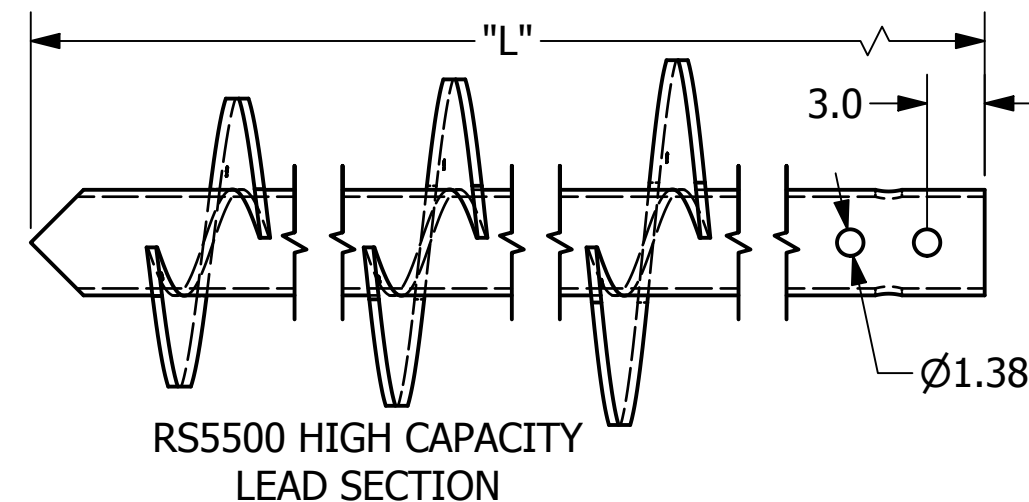

<b>CHANCE</b> <sup>®</sup> <small>CONFIDENTIAL: THIS DRAWING AND ITS CONTENTS ARE CONFIDENTIAL AND THE EXCLUSIVE PROPERTY OF HUBBELL POWER SYSTEMS. NO PUBLICATION, DISTRIBUTION, OR COPIES MAY BE MADE WITHOUT THE WRITTEN CONSENT OF HUBBELL POWER SYSTEMS. HUBBELL POWER SYSTEMS UNPUBLISHED ALL RIGHTS RESERVED UNDER THE COPYRIGHT LAWS.</small>	HUBBELL POWER SYSTEMS, INC.		
	TITLE <b>RS5500.361 HCP LEADS, EXTENSIONS, AND CAPS</b>		
SIZE <b>B</b>	CAT / PART / ASSY NO. <b>SEE TABLES</b>	DWG NO. <b>SA1073065</b>	REV <b>B</b>
DO NOT SCALE THIS DRAWING	DRN BY APB	DATE 2/19/20	SHEET 1 OF 1