

# COMPRESSION/TENSION NEW CONSTRUCTION CAPS FOR SQUARE SHAFTS

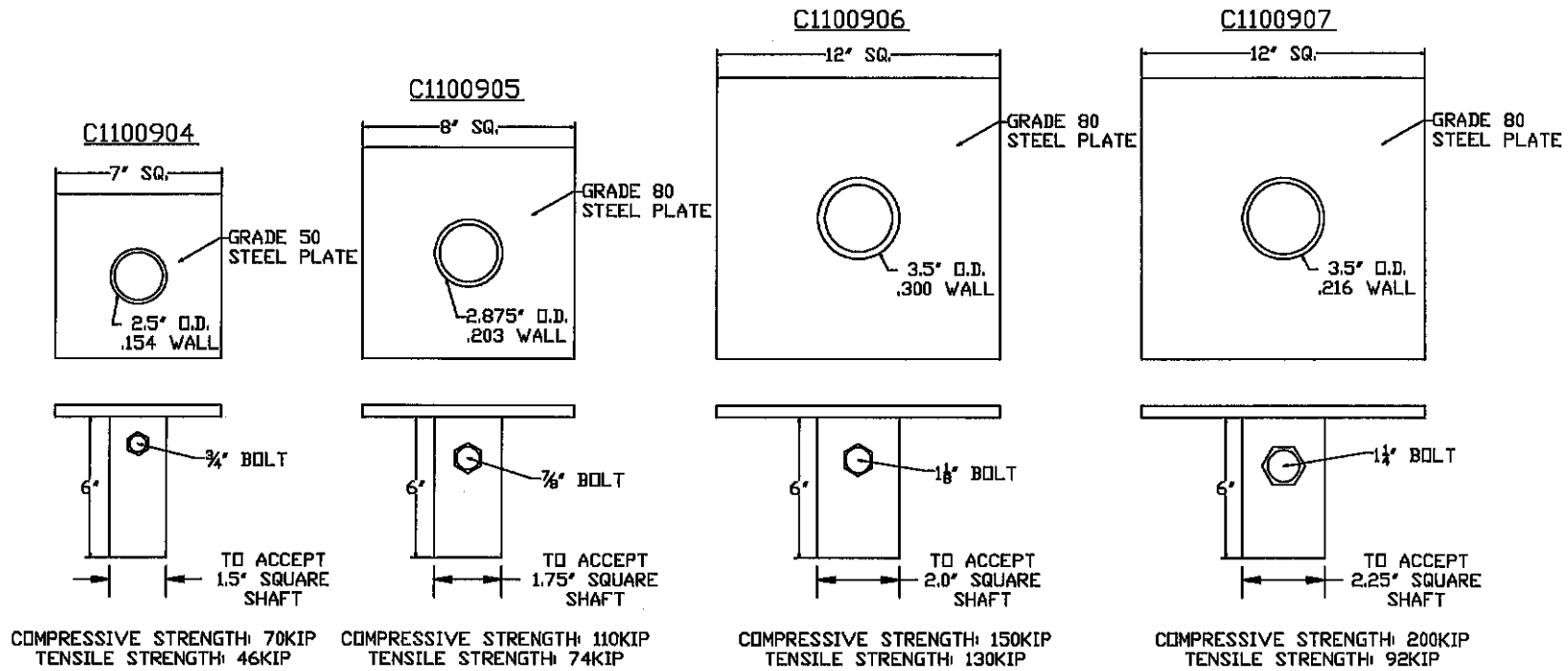

## =NOTES=

1. FINISH: STANDARD CATALOG NUMBER IS MILL FINISH STEEL.  
TO ORDER GALVANIZED FINISH ADD 'G' TO STANDARD CATALOG NUMBER.
2. MATERIAL SPECIFICATIONS:  
 PLATE: HOT ROLLED STEEL PLATE PER ASTM A572 GRD. 50.  
 OR HOT ROLLED STEEL PLATE PER ASTM A656 GRD. 80.  
 PIPE: ERW PIPE PER ASTM A53 GRADE B OR PER ASTM 500 GRADE 50.  
 BOLT: 3/4" HEX HEAD BOLTS PER ASTM A325 TYPE 1.  
 7/8", 1-1/8", AND 1-1/4" HEX HEAD BOLTS PER ASTM A193.

<b>CHANCE</b> TOLERANCE CHART	<b>HUBBELL POWER SYSTEMS</b> <small>HUBBELL POWER SYSTEMS, INC.</small>		
TITLE: BRACKET, COMPRES./TEN. NEW CONSTRUCTION			
CONFIDENTIAL: THIS DRAWING AND ITS CONTENTS ARE CONFIDENTIAL AND THE EXCLUSIVE PROPERTY OF HUBBELL POWER SYSTEMS. NO PUBLICATION, DISTRIBUTION OR COPIES MAY BE MADE WITHOUT THE WRITTEN CONSENT OF HUBBELL POWER SYSTEMS. HUBBELL POWER SYSTEMS UNPUBLISHED. ALL RIGHTS RESERVED UNDER THE COPYRIGHT LAWS.	SIZE: DRG NO. SB SA1100904	CAT / PART / ASSY NO. SEE DRAWING	REV --
DO NOT SCALE THIS DRAWING	DRN BY: TLW	DATE: 11/24/10	SHEET 1 OF 1