

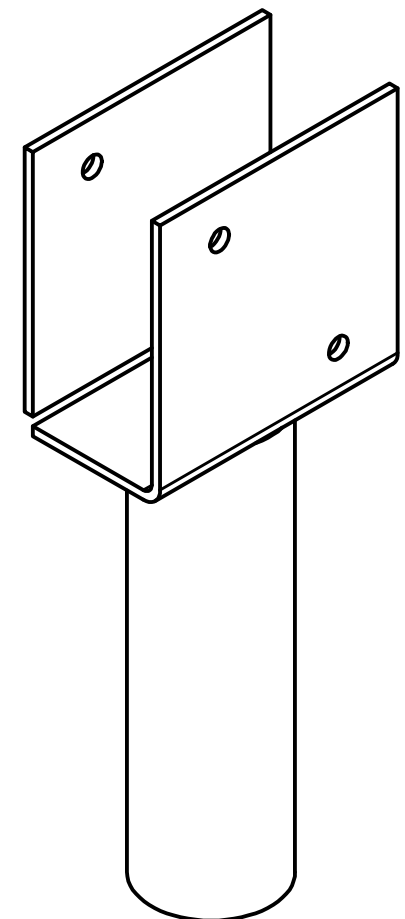

TO ACCEPT  
RS2875 PILE

==NOTES==

1. FINISH: HOT DIPPED GALVANIZED PER ASTM A153 (LATEST REV).
2. 10,000 LB MAX LOAD COMPRESSION ONLY
3. BOLTS: 1/2" DIA HEX HEAD, 4.5" LONG WITH NUT AND LOCK WASHER SUPPLIED BY OTHERS
4. MATERIAL:
  - SADDLE: 1/4" THICK HOT ROLLED STEEL



<b>CHANCE</b> <sup>®</sup>		 <b>HUBBELL POWER SYSTEMS, INC.</b>			
		TITLE <b>WALKWAY SUPPORT BRACKET</b>			
<small>CONFIDENTIAL: THIS DRAWING AND ITS CONTENTS ARE CONFIDENTIAL AND THE EXCLUSIVE PROPERTY OF HUBBELL POWER SYSTEMS. NO PUBLICATION, DISTRIBUTION, OR COPIES MAY BE MADE WITHOUT THE WRITTEN CONSENT OF HUBBELL POWER SYSTEMS. HUBBELL POWER SYSTEMS UNPUBLISHED ALL RIGHTS RESERVED UNDER THE COPYRIGHT LAWS.</small>		SIZE <b>B</b>	CAT / PART / ASSY NO. <b>C1100936</b>	DWG NO. <b>SA110936</b>	REV <b>A</b>
<small>DO NOT SCALE THIS DRAWING</small>		DRN BY BLJ	DATE 6/15/18	SHEET 1 OF 1	