

-NOTES-

1. BASE MATERIAL: STEEL PLATE PER ASTM A36, 1/4" THICK. TRIANGLE GUSSET MATERIAL: STEEL PLATE PER ASTM A36, 3/8" THICK.
2. FINISH: HOT DIP GALVANIZED PER ASTM A153-(LATEST REVISION).
3. ONE PAIR OF POLE SUPPORTS ADDS 245 IN<sup>2</sup> OF AREA TO BOTTOM OF POLE.  
TWO PAIRS OF POLE SUPPORTS ADD 490 IN<sup>2</sup> OF AREA TO BOTTOM OF POLE.
4. PLATE AND HARDWARE AVAILABLE IN KITS.

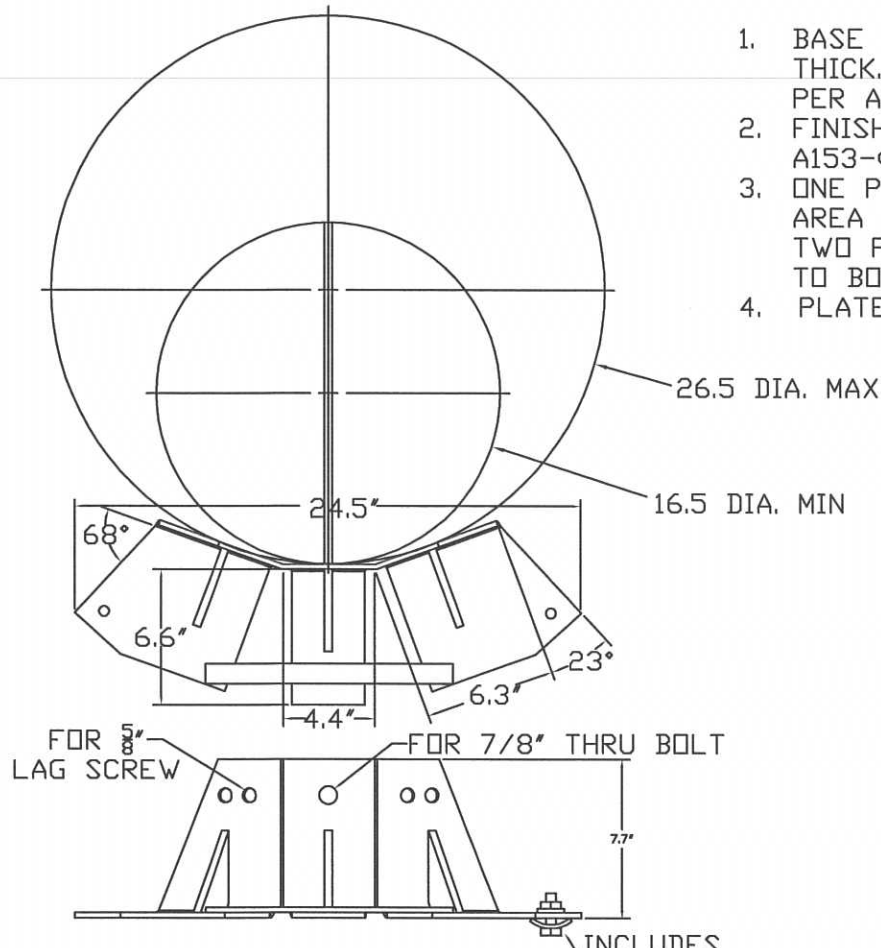

CAT. NO. C1100954  
(SOLD AS A SINGLE UNIT, NOT IN PAIRS)

INCLUDES  
GROUNDING  
LUG,  
CURVED  
WASHER,  
& LOCK  
WASHER.

SCREWS (SOLD SEPARATELY)		
DESC.	CAT. NO.	LENGTH
5/8" LAG SCREW	PSC2050528	4.5"

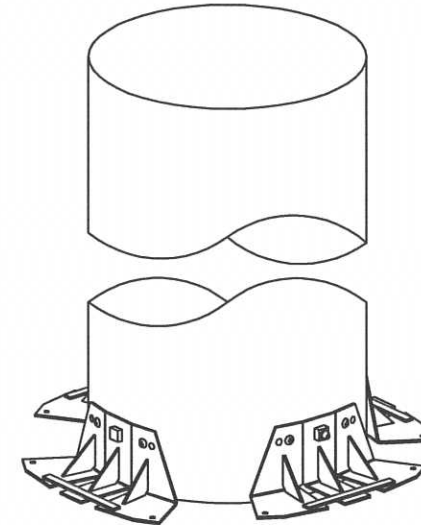

<b>CHANCE</b> TOLERANCE CHART <small>SEE DRAWING FOR TOLERANCE CHART                  UNLESS OTHERWISE SPECIFIED                  DIMENSIONS ARE IN INCHES</small>		<b>HUBBELL</b> POWER SYSTEMS <small>POWER SYSTEMS</small>	
<small>CONFIDENTIAL: THIS DRAWING AND ITS CONTENTS ARE CONFIDENTIAL AND THE EXCLUSIVE PROPERTY OF HUBBELL POWER SYSTEMS. NO PUBLICATION, DISTRIBUTION OR COPIES MAY BE MADE WITHOUT THE WRITTEN CONSENT OF HUBBELL POWER SYSTEMS. HUBBELL POWER SYSTEMS UNPUBLISHED. ALL RIGHTS RESERVED UNDER THE COPYRIGHT LAWS.</small>		TITLE <b>POLE BEARING ASSEMBLY, LARGE</b>	
SIZE C	DWG NO. SA1100954	CAT / PART / ASSY NO. C1100954	REV A
DO NOT SCALE THIS DRAWING		DRN BY HERVATH DATE 6/25/2015 SHEET 1 OF 1	