

COMPRESSION/TENSION NEW CONSTRUCTION PILE CAPS

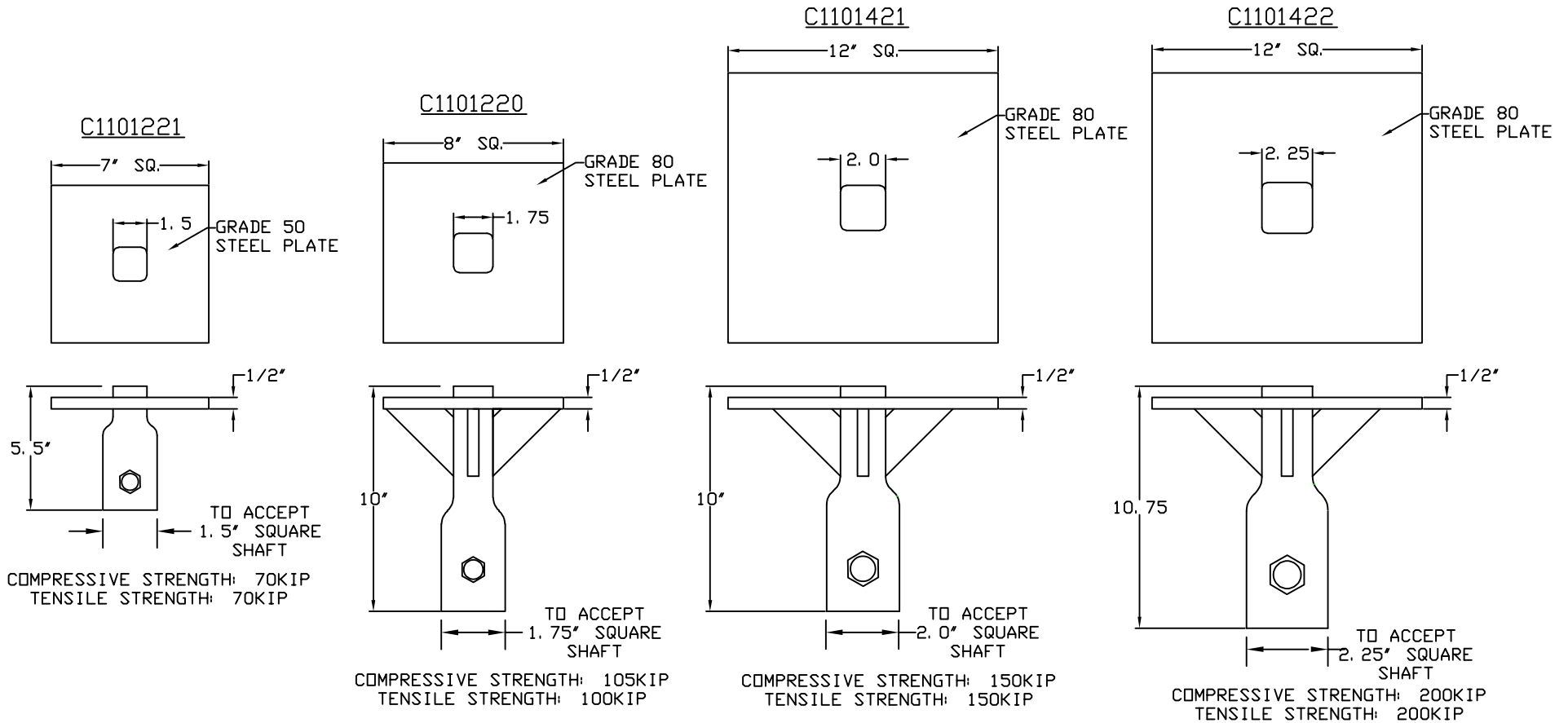

=NOTES=

1. FINISH: STANDARD CATALOG NUMBER IS MILL FINISH STEEL.
 TO ORDER GALVANIZED FINISH ADD "G" TO STANDARD CATALOG NUMBER.
2. MATERIAL SPECIFICATIONS:
 PLATE: HOT ROLLED STEEL PLATE PER ASTM A572 GRD. 50,
 OR HOT ROLLED STEEL PLATE PER ASTM A656 GRD. 80.
 SOCKET: ROUND CORNER SQUARE STEEL BAR PER TT-76
 BOLT: HEX HEAD BOLTS PER ASTM A193.

CHANCE TOLERANCE CHART	HUBBELL® POWER SYSTEMS		
	TITLE COMPRESSION/TENSION NEW CONSTRUCTION PILE CAP		
CONFIDENTIAL: THIS DRAWING AND ITS CONTENTS ARE CONFIDENTIAL AND THE EXCLUSIVE PROPERTY OF HUBBELL POWER SYSTEMS. NO PUBLICATION, DISTRIBUTION OR COPIES MAY BE MADE WITHOUT THE WRITTEN CONSENT OF HUBBELL POWER SYSTEMS. HUBBELL POWER SYSTEMS UNPUBLISHED ALL RIGHTS RESERVED UNDER THE COPYRIGHT LAWS.	SIZE DWG NO. SB SA1101221	CAT / PART / ASSY NO. SEE DRAWING	REV A
	DO NOT SCALE THIS DRAWING	DRN BY BLJ	DATE 7/22/24
	SHEET 1 OF 1		