

==NOTES==

1. FINISH: GALVANIZE PER ASTM A123 (LATEST REVISION)
2. SEE SALES DRAWING FOR HARDWARE PACKS. SA1101707 FOR RS4500.337 AND SA1101708 FOR RS 3500.300.
3. MATERIAL:
  - A. PLATE: PLATE STEEL PER ASTM A572 GRD 50
  - B. PILE TUBES: HSS 10X10X1/2 PER ASTM A500 GRD B, MIN 50 KSI
  - C. THREADBAR: 1.5-6UNC-2A THREADED ROD PER AISI 4130 HOT ROLLED STEEL
4. ESTIMATED WEIGHT: 4,600 LBS

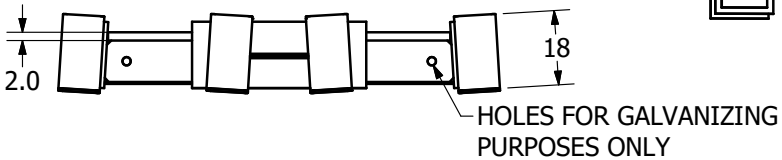

THREADBAR WITH FORGED OR WELDED PUCK

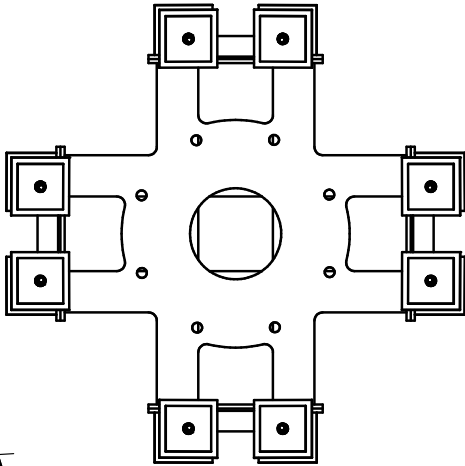
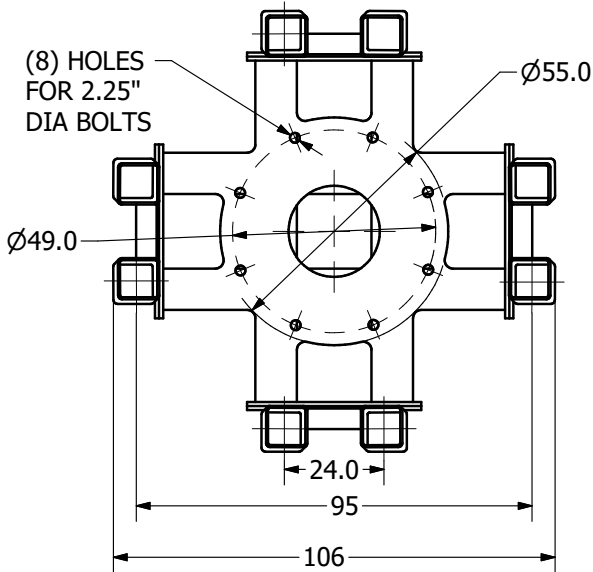
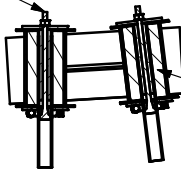

SQUARE TUBE FILLED WITH NONSHRINK GROUT MINIMUM 4000 PSI COMPRESSIVE STRENGTH \*PROVIDED BY OTHERS\*

SECTION A-A

GRILLAGE NO PILES

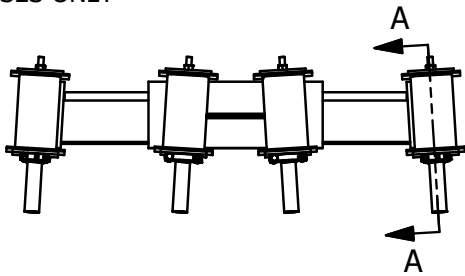

GRILLAGE WITH PILES

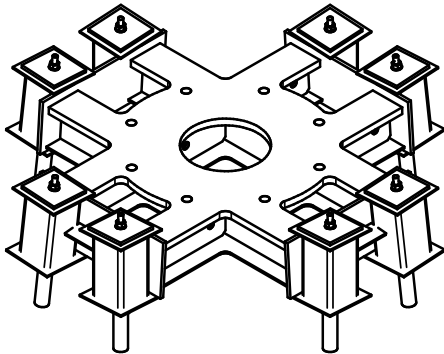
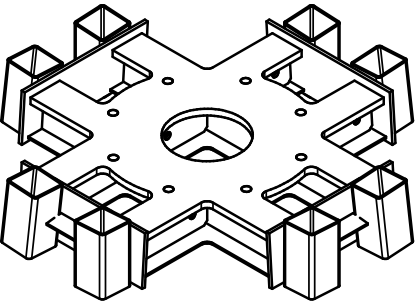

<b>CHANCE</b> ®		<b>HUBBELL</b> ® POWER SYSTEMS, INC.	
TITLE			
<b>8 PILE GRILLAGE</b>			
SIZE	CAT / PART / ASSY NO.	DWG NO.	REV
<b>B</b>	<b>C1102062</b>	<b>SA1102062</b>	<b>A</b>
DO NOT SCALE THIS DRAWING		DRN BY BLJ	DATE 2/8/2022
		SHEET 1 OF 1	

CONFIDENTIAL: THIS DRAWING AND ITS CONTENTS ARE CONFIDENTIAL AND THE EXCLUSIVE PROPERTY OF HUBBELL POWER SYSTEMS. NO PUBLICATION, DISTRIBUTION, OR COPIES MAY BE MADE WITHOUT THE WRITTEN CONSENT OF HUBBELL POWER SYSTEMS, HUBBELL POWER SYSTEMS UNPUBLISHED ALL RIGHTS RESERVED UNDER THE COPYRIGHT LAWS.