

HARDWARE:

- (4) .625" X 2.5" GR. 5 CARR. BOLT
- (4) .625" HEX NUT
- (4) .625" RETAINING WASHERS

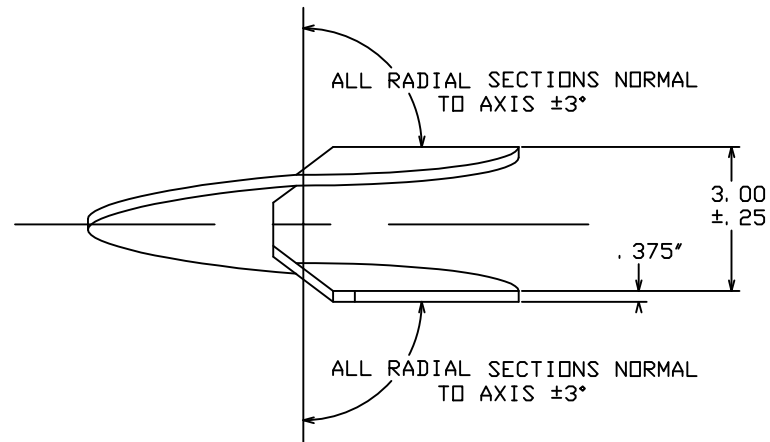

HELIX MUST BE FORMED BY MATCHING METAL DIE

VIEW A-A

(SIDE VIEW OF TRUE HELICAL FORM)

MAT'L: HOT DIP GALVANIZED STEEL

*LIGHTING FOUNDATION
CAT. NO. T112-0302*

CHANCE		HUBBELL POWER SYSTEMS	
CONFIDENTIAL: THIS DRAWING AND ITS CONTENTS ARE CONFIDENTIAL AND THE EXCLUSIVE PROPERTY OF HUBBELL POWER SYSTEMS. NO PUBLICATION, DISTRIBUTION OR COPIES MAY BE MADE WITHOUT THE WRITTEN CONSENT OF HUBBELL POWER SYSTEMS. HUBBELL POWER SYSTEMS UNPUBLISHED. ALL RIGHTS RESERVED UNDER THE COPYRIGHT LAWS.		TITLE LIGHTING FOUNDATION	
SIZE	DWG NO.	REV	C
SC	SA112-0302	DO NOT SCALE THIS DRAWING	DRN BY KSH DATE 11/5/04 SHEET 1/1