

RECOMMENDED TORQUE
NO GREATER THAN
10,000 FT-LB

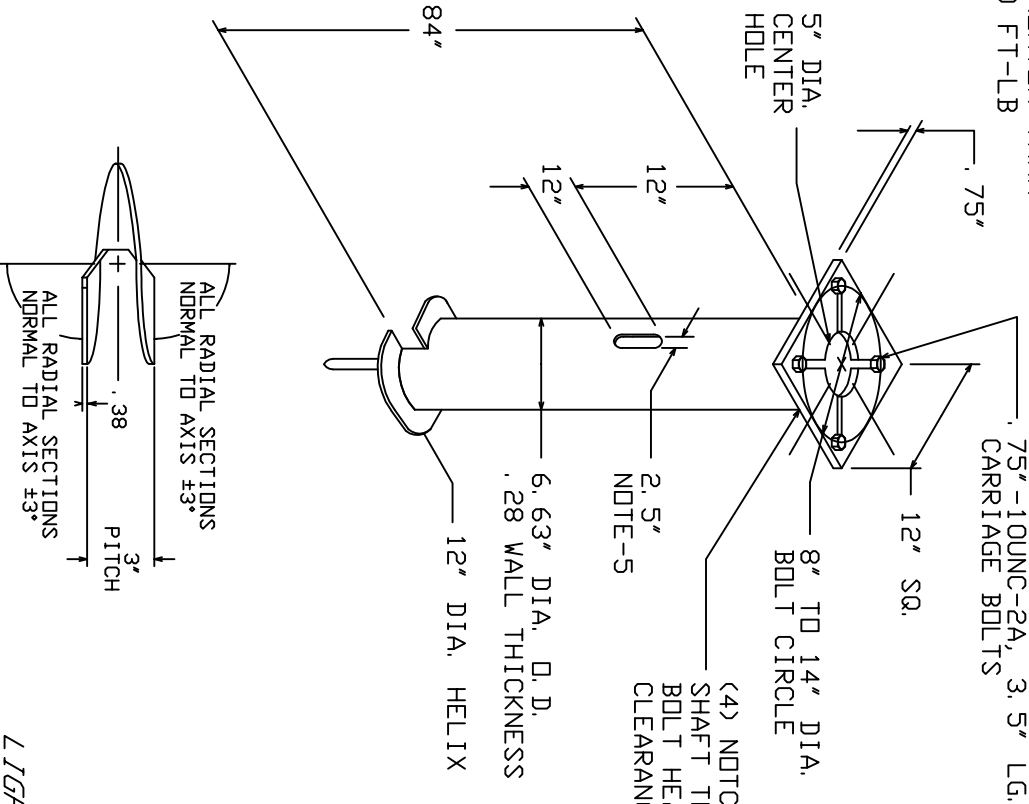

HELIX MUST BE FORMED BY MATCHING METAL DIE
(SIDE VIEW OF TRUE HELICAL FORM)

LIGHTING FOUNDATION
CATALOG NUMBER
T1120844

-NOTES-

1. FINISH: HOT DIP GALVANIZE PER ASTM-A153 (LATEST REVISION). BASEPLATE TO BE PERPENDICULAR TO SHAFT AXIS ($\pm 1^\circ$) AND HOLE CENTERLINE CONCENTRIC ($\pm .188$) TO SHAFT AXIS.
2. STENCIL MIN. 1/2 IN. LETTERS MANUFACTURER'S NUMBER AFTER GALVANIZING.
3. PILOT POINT AND SHAFT AXES TO BE CONCENTRIC ($\pm .125$ FIM) AND IN LINE ($\pm 2^\circ$).
4. FLAME CUT TWO SLOTS IN SHAFT PERPENDICULAR TO THE BASEPLATE. PREHEAT, TUMBLEBLAST, HANDGRIND, AND CLEAN BASEPLATE, HELIX, AND PILOT POINT ON ALL WELDED AREAS.
5. FLAMECUT IRREGULARITIES PERMISSIBLE: (1) VALLEYS NOT TO EXCEED 3/32 IN. BELOW NOMINAL SURFACE LEVEL, (2) PEAKS OR POSITIVE IRREGULARITIES NOT TO EXCEED 1/32 IN. ABOVE NOMINAL SURFACE LEVEL OR INTERSECTIONS OF NOMINAL SURFACES.
6. MANUFACTURER TO HAVE IN EFFECT INDUSTRY RECOGNIZED WRITTEN QUALITY CONTROL FOR ALL MATERIALS AND MANUFACTURING PROCESSES. ALL MATERIAL IS TO BE NEW, UNUSED AND MILL TRACEABLE MEETING THE FOLLOWING SPECIFICATIONS:
7. BASEPLATE: ASTM A36-(LATEST REVISION) STRUCTURAL STEEL (CONFORM TO AASHTO TECH. BUL. #270)
8. SHAFT: ASTM A252-(LATEST REVISION) GRADE 2, STEEL PIPE PILES. ALTERNATE MATERIAL: ASTM A53-(LATEST REVISION) TYPE E OR S, GRADE B, STEEL PIPE OR ASTM A500-(LATEST REVISION) GRADE B, STRUCTURAL STEEL TUBING.
9. HELIX: ASTM A635-(LATEST REVISION) 3/8" THICK HOT ROLLED STEEL PLATE OR COIL.
10. PILOT POINT: ASTM A575 (LATEST REVISION) 1-1/4" DIAMETER HOT ROLLED STEEL BAR.
11. BOLTS: CARRIAGE BOLTS, 3/4-10UNC-2A PER ANSI B-18.5, SAE J429 GRADE-5.
12. BASEPLATE IS PERMANENTLY STAMPED WITH MANUFACTURER'S IDENTIFICATION "ABC" IN 1/2" LETTERS AND THE JULIAN DATE CODE IN 1/4" LETTERS.
13. BOLT CLEARANCE SLOTS IN SHAFT UNDER BASEPLATE. MAXIMUM GROUNDLINE BENDING MOMENT CANNOT EXCEED 13,000 FT.-LBS. ON THIS DESIGN. IF DESIGN REQUIREMENTS EXCEED THIS LIMIT, CONTACT THE MANUFACTURER FOR OTHER ALTERNATIVES.
14. BASEPLATE PERMANENTLY MARKED TO INDICATE CABLEWAY OPENING IN SHAFT.

CHANCE			
CONFIDENTIAL: THIS DRAWING AND ITS EXCLUSIVE PROPERTY OF HUBBELL POWER SYSTEMS. NO PUBLICATION, DISTRIBUTION OR COPIES MAY BE MADE WITHOUT THE WRITTEN CONSENT OF HUBBELL POWER SYSTEMS UNPUBLISHED. ALL RIGHTS RESERVED UNDER THE COPYRIGHT LAWS.		HUBBELL POWER SYSTEMS	
TITLE LIGHTING FOUNDATION		DRAWING NO. S11120844	
DO NOT SCALE THIS DRAWING		REV A	
DATE 6/1/07		SHEET 1/1	