

1" SEMI-CONDUCTIVE NYLON THREAD

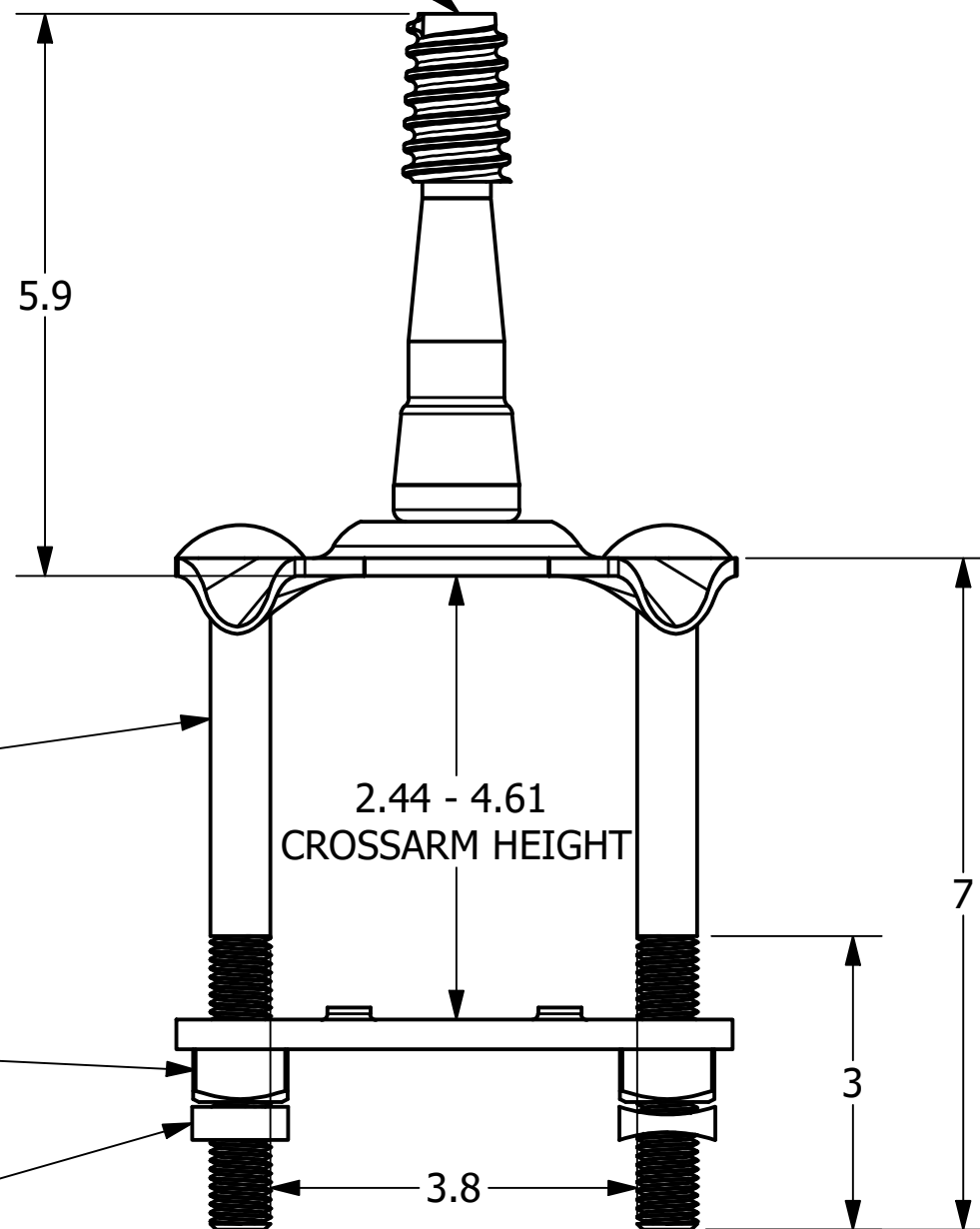

5/8" CARRIAGE BOLT

5/8" SQUARE NUT

5/8" LOCKNUT

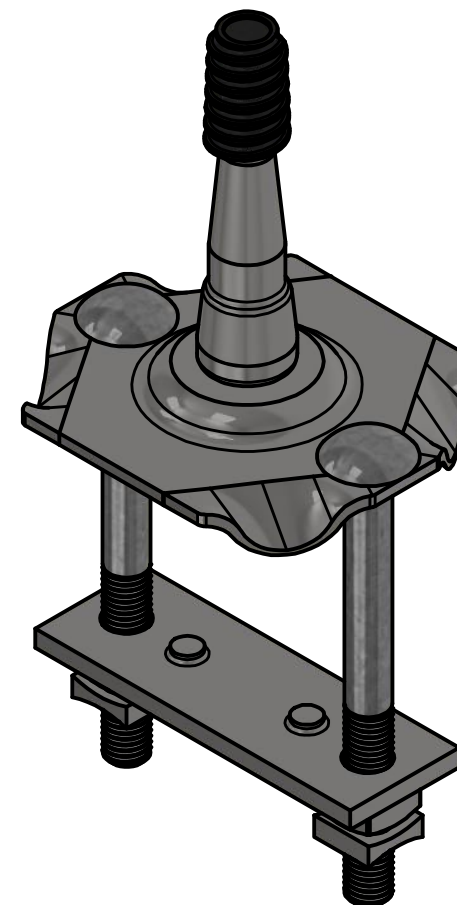

NOTES

1. MATERIAL: STEEL PER ASTM A575
2. FINISH: HOT DIP GALVANIZE PER ASTM A153
3. HARDWARE PER IEEE C135. 1

CATALOG NUMBER: 14322P

CHANCE®



HUBBELL POWER SYSTEMS, INC.

CONFIDENTIAL: THIS DRAWING AND ITS CONTENTS ARE CONFIDENTIAL AND THE EXCLUSIVE PROPERTY OF HUBBELL POWER SYSTEMS. NO PUBLICATION, DISTRIBUTION, OR COPIES MAY BE MADE WITHOUT THE WRITTEN CONSENT OF HUBBELL POWER SYSTEMS. HUBBELL POWER SYSTEMS UNPUBLISHED ALL RIGHTS RESERVED UNDER THE COPYRIGHT LAWS.

TITLE		STRAIGHT CORNER PIN	
SIZE	CAT / PART / ASSY NO.	DWG NO.	REV
B	14322P	SA14322P	C
DO NOT SCALE THIS DRAWING	DRN BY KARDON	DATE 02/28/2022	SHEET 1 OF 1