

SS175 EXTENSIONS

TORQUE STRENGTH RATING-10,500 FT-LB
 ULTIMATE CAPACITY* (TENSION/COMPRESSION)-105 KIP
 * BASED ON A TORQUE FACTOR (Kt)=10
 PER ICC-ES AC308 SECTION 3.13.2
 NOMINAL TENSION STRENGTH (COUPLING BOLT)-100 KIP

EXTENSION SECTION						
CAT. NO.	A	B	C	E	F	ICC-ES LISTED ESR-2794
C150-0183	38"					X
C150-0013	59"					X
C150-0014	80"					X
C150-0184	124"					X
C150-0037	20"					
C114-0010	12"					
C150-0185	46"	14"		37"		X
C150-0186	80"	14"	14"	36"	8"	X

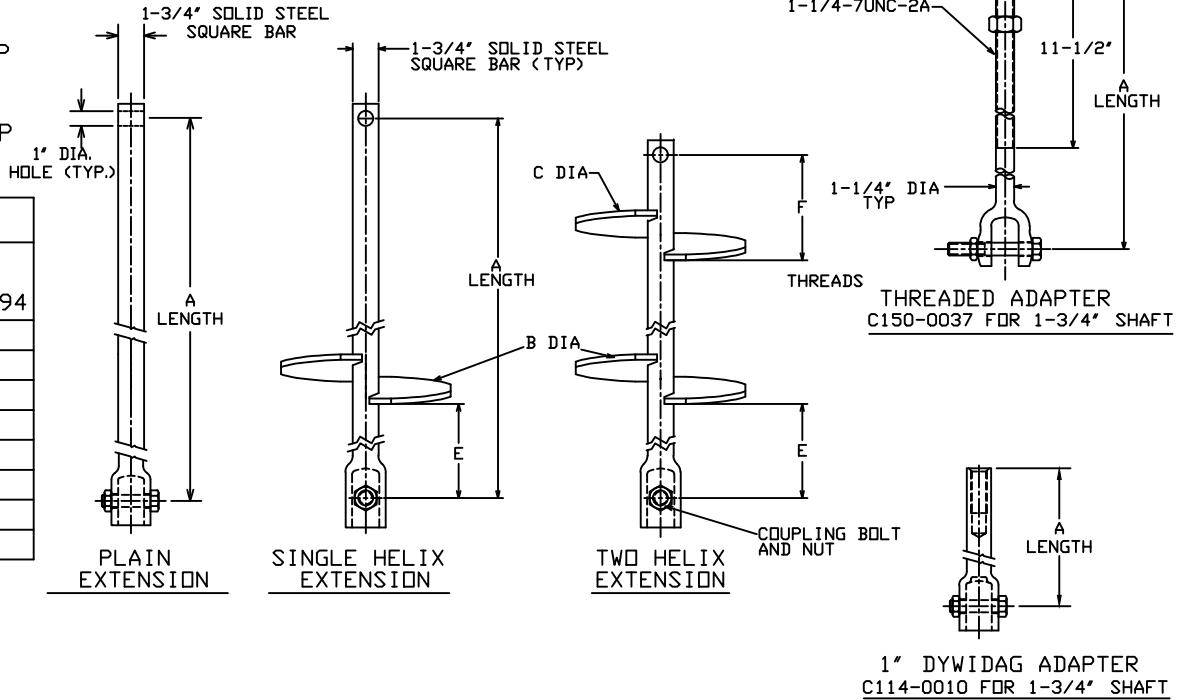

==NOTES==

- HOT DIP GALVANIZED PER ASTM A153-(LATEST REVISION).
- LEAD AND EXTENSION SECTION LENGTHS AND HELIX SPACINGS ARE NOMINAL.
- SHAFT MATERIAL-HOT ROLLED ROUND-CORNERED-SQUARE (RCS) SOLID STEEL BARS PER ASTM A29; MINIMUM YIELD STRENGTH=90 KSI.
- COUPLING BOLTS: 7/8" DIAMETER X 3-1/2" LONG HEX HEAD PER ASTM A193 GRADE B7.
- MANUFACTURER TO HAVE IN EFFECT INDUSTRY RECOGNIZED WRITTEN QUALITY CONTROL FOR ALL MATERIALS AND MANUFACTURING PROCESSES.
- ALL WELDING TO BE DONE BY WELDERS CERTIFIED UNDER SECTION 5 OF THE AWS CODE D1. 1.
- SEE ICC EVALUATION SERVICE INC., EVALUATION REPORT NO. ESR-2794 FOR NOMINAL, DESIGN, AND ALLOWABLE STRENGTH VALUES AND/OR CONDITIONS OF USE CONCERNING INFORMATION PRESENTED ON THIS DRAWING.
- REFER TO SA150-10012 FOR LEAD SECTIONS AND HELICAL EXTENSIONS.

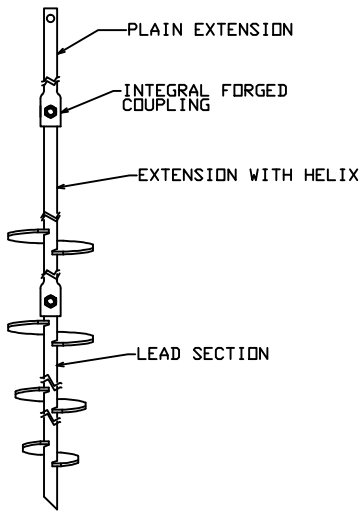

TYPICAL ANCHOR/PILE ASSEMBLY

ICC-ES LISTED ESR-2794

CHANCE	HUBBELL POWER SYSTEMS		
CONFIDENTIAL: THIS DRAWING AND ITS CONTENTS ARE CONFIDENTIAL AND THE EXCLUSIVE PROPERTY OF HUBBELL POWER SYSTEMS. NO PUBLICATION, DISTRIBUTION OR COPIES MAY BE MADE WITHOUT THE WRITTEN CONSENT OF HUBBELL POWER SYSTEMS. HUBBELL POWER SYSTEMS UNPUBLISHED. ALL RIGHTS RESERVED UNDER THE COPYRIGHT LAWS.			
TITLE SS175 EXTENSIONS		SIZE SC SA150-0183	REV B
DO NOT SCALE THIS DRAWING	DRN BY KSH	DATE 4/12/06	SHEET 2/2