

SS125 EXTENSIONS

TORQUE STRENGTH RATING - 4,000 FT-LB
 ULTIMATE CAPACITY (TENSION/COMPRESSION)-40 KIP
 * BASED ON A TORQUE FACTOR (K_t)=10
 ULTIMATE TENSION STRENGTH (COUPLING BOLT)-50 KIP

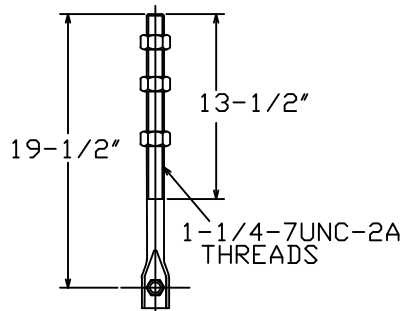

THREADED ADAPTER
 C1500580 FOR
 1-1/4" SHAFT

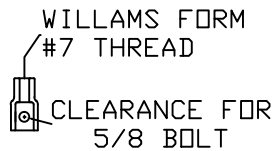

PSA15710
 THREADBAR
 TRANSITION

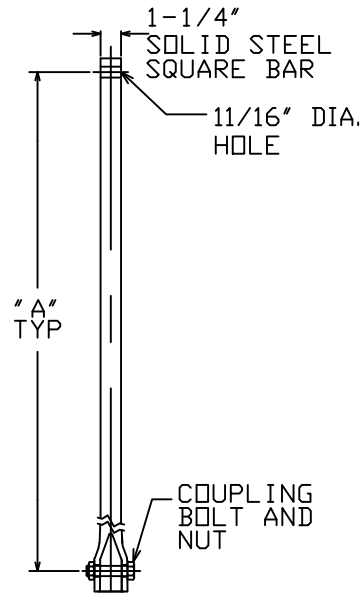

PLAIN
 EXTENSION

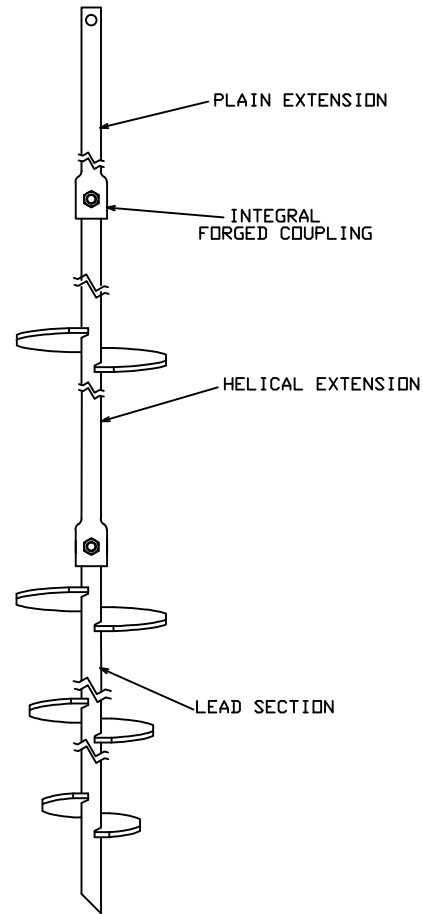

EXTENSION	
CAT. NO.	"A"
C1500553	38"
C1500554	57-3/4"
C1500555	80-3/4"
C1500556	120-1/4"

-NOTES-

- HOT DIP GALVANIZED PER ASTM A153-(LATEST REV.)
- LEAD AND EXTENSION SECTION AND PILOT POINT LENGTHS ARE NOMINAL.
- SHAFT MATERIAL-HOT ROLLED ROUND-CORNERED-SQUARE (RCS) SOLID STEEL BARS PER ASTM A29; MINIMUM YIELD STRENGTH=90 KSI.
- COUPLING BOLTS: 3/4" DIAMETER X 3" LONG HEX HEAD PER ASTM A325 TYPE 1.
- MANUFACTURER TO HAVE IN EFFECT INDUSTRY RECOGNIZED WRITTEN QUALITY CONTROL FOR ALL MATERIALS AND MANUFACTURING PROCESSES.
- ALL WELDING TO BE DONE BY WELDERS CERTIFIED UNDER SECTION 5 OF THE AWS CODE D1.1.
- REFER TO SA1500545 DRAWING FOR LEAD SECTIONS AND HELICAL EXTENSIONS.

CHANCE		 HUBBELL POWER SYSTEMS POWER SYSTEMS, INC.	
CONFIDENTIAL: THIS DRAWING AND ITS CONTENTS ARE CONFIDENTIAL AND THE EXCLUSIVE PROPERTY OF HUBBELL POWER SYSTEMS, INC. NO PUBLICATION, DISTRIBUTION OR COPIES MAY BE MADE WITHOUT THE PRIOR WRITTEN CONSENT OF HUBBELL POWER SYSTEMS, INC. HUBBELL POWER SYSTEMS UNPUBLISHED ALL RIGHTS RESERVED UNDER THE COPYRIGHT LAWS.		SS125 EXTENSIONS	
SIZE	DWG NO.	REV	
A	SA1500553	-	
DO NOT SCALE THIS DRAWING	DRN BY LMM	DATE 05/19/08	SHEET SHT