

TORQUE RATING: 8,000 FT-LBS  
TENSION RATING: 80 KIP

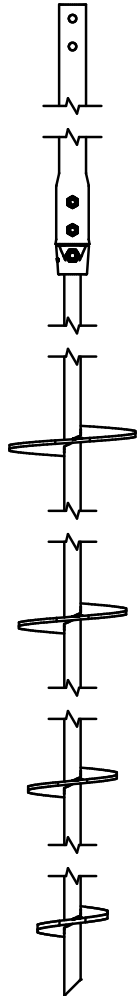

TYPICAL PIER ASSEMBLY

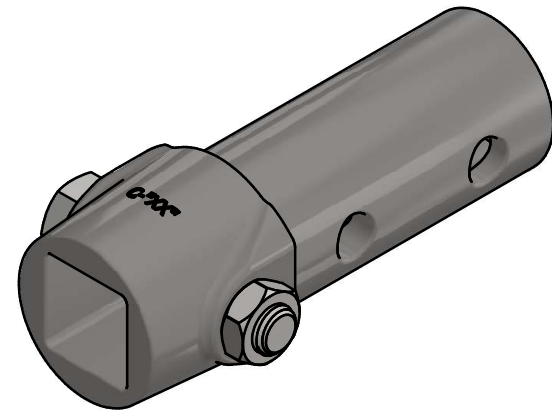
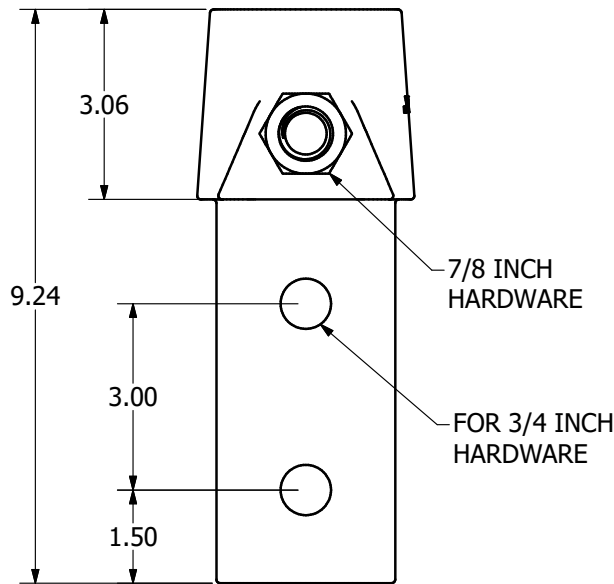
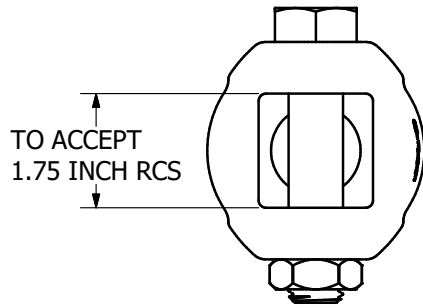

\* \* NOTES \* \*

1. MAT'L: CAST DUCTILE IRON PER ASTM A536 60-40-18
2. FINISH: HOT DIP GALVAINZE PER ASTM A153
3. HARDWARE: INCLUDES (1) 7/8 INCH HES HEAD BOLT AND NUT PER ASTM A193 GRADE B7.

PILE LENGT	ULTIMATE CAPACITY TENSION/ COMPRESSION			
	Kt (SAND)	CAPACITY (	Kt (CLAY)	CAPACITY (
> 30'-0"	10	80 KIP	9.5	76 KIP
≥ 30'-0"	9.5	76 KIP	9.5	76 KIP

<p><b>CHANCE</b>®</p> <p><small>CONFIDENTIAL: THIS DRAWING AND ITS CONTENTS ARE CONFIDENTIAL AND THE EXCLUSIVE PROPERTY OF HUBBELL POWER SYSTEMS. NO PUBLICATION, DISTRIBUTION, OR COPIES MAY BE MADE WITHOUT THE WRITTEN CONSENT OF HUBBELL POWER SYSTEMS, HUBBELL POWER SYSTEMS UNPUBLISHED ALL RIGHTS RESERVED UNDER THE COPYRIGHT LAWS.</small></p>	<p><b>HUBBELL</b>® POWER SYSTEMS, INC.</p> <p>HUBBELL POWER SYSTEMS, INC.</p>			<p>HUBBELL POWER SYSTEMS, INC.</p>	
	<p>TITLE</p> <p><b>TRANSITION, CAST</b> <b>SS175 TO RS2875</b></p>				
<p>SIZE</p> <p><b>B</b></p>	<p>CAT / PART / ASSY NO.</p> <p><b>C1501365</b></p>	<p>DWG NO.</p> <p><b>SA1501365</b></p>	<p>REV</p> <p><b>A</b></p>	<p>DO NOT SCALE THIS DRAWING</p>	
<p>DRN BY OJS</p>		<p>DATE 3/19/2020</p>	<p>SHEET 1 OF 1</p>		