

ROCK-IT™

SS150 HELICAL LEAD SECTION

TORQUE STRENGTH RATING: 7,000 FT-LB
 ULTIMATE CAPACITY* (TENSION/COMPRESSION): 70,000 LB
 *BASED ON A TORQUE FACTOR (Kt=10)
 ULTIMATE TENSION STRENGTH (COUPLING BOLT): 70,000 LB

PART NUMBER	DESCRIPTION	'A'	'B'	'C'	'D'	'E'	'F'	'G'
C1501488	LEAD, SS150, 6/8 X 3FT, ROCK-IT™	36.6	31.0	6	8	-	-	1.5
C1501489	LEAD, SS150, 8/10 X 3FT, ROCK-IT™	36.6	31.0	8	10	-	-	1.5
C1501505	LEAD, SS150, 8/10 X 5FT, ROCK-IT™	64.3	59.0	8	10	-	-	1.5
C1501833	LEAD, SS150, 10/12 X 5FT, ROCK-IT™	64.3	59.0	10	12	-	-	1.5
C1501835	LEAD, SS150, 6/8/10 X 5FT, ROCK-IT™	64.3	59.0	6	8	10	-	1.5
C1501907	LEAD, SS150, 10 X 5FT, ROCK-IT™	64.3	59.0	10	-	-	-	1.5
C1501934	LEAD, SS150, 8/10/12 X 5FT, ROCK-IT™	64.3	59.0	8	10	12	-	1.5

SS175

TORQUE STRENGTH RATING: 10,500 FT-LB
 ULTIMATE CAPACITY* (TENSION/COMPRESSION): 105,000 LB
 *BASED ON A TORQUE FACTOR (Kt=10)
 ULTIMATE TENSION STRENGTH (COUPLING BOLT): 100,000 LB

PART NUMBER	DESCRIPTION	'A'	'B'	'C'	'D'	'E'	'F'	'G'
C1501507	LEAD, SS175, 8/10 X 5FT, ROCK-IT™	64.3	59.0	8	10	-	-	1.75
C1501509	LEAD, SS175, 8/10/12 X 5FT, ROCK-IT™	64.3	59.0	8	10	12	-	1.75
C1501511	LEAD, SS175, 6/8 X 3FT, ROCK-IT™	36.6	31.0	6	8	-	-	1.75
C1502059	LEAD, SS175, 6/8 X 5FT, ROCK-IT™	64.3	59	6	8	-	-	1.75
C1502181	LEAD, SS175, 6/8 X 7FT, ROCK-IT™	82.8	77.5	6	8	-	-	1.75
C1501513	LEAD, SS175, 8/10 X 3FT, ROCK-IT™	36.6	31.0	8	10	-	-	1.75
C1501725	LEAD, SS175, 6/8/10 X 5FT, ROCK-IT™	64.3	59.0	6	8	10	-	1.75
C1502057	LEAD, SS175, 6/8/10/12 X 7FT, ROCK-IT™	82.8	77.5	6	8	10	12	1.75

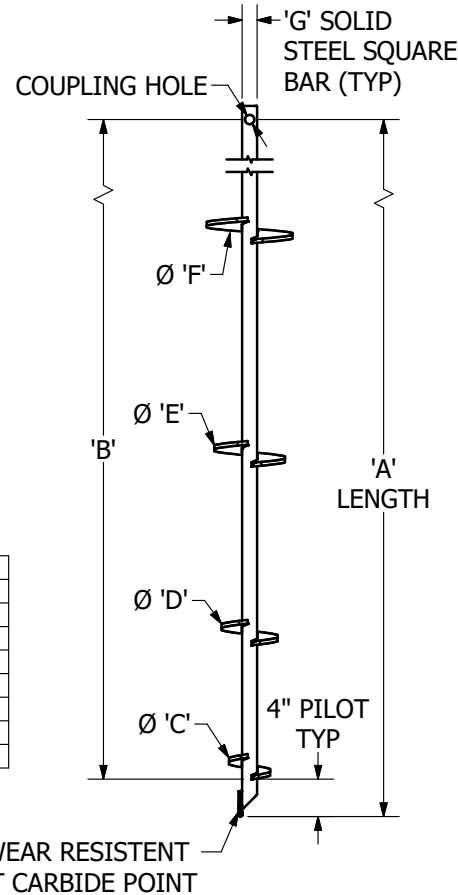

** NOTES **

- HOT DIP GALVANIZED PER ASTM A153 (LATEST REV).
- LEAD SECTION LENGTHS AND HELIX SPACINGS ARE NOMINAL.
- SHAFT MATERIAL: HOT HOLLOWED ROUND-CORNER-SQUARE(RCS) SOLID STEEL BARS PER ASTM A29; MINIMUM YIELD STRENGTH: 90 KSI.
- HELIX MATERIAL: HOT ROLLED CARBON STEEL PER ASTM A656, GRADE 80.
- COUPLING BOLTS PER ASTM A193 GRADE B7.
- NOMINAL SPACING BETWEEN HELIX PLATES IS THREE TIMES THE DIAMETER OF THE LOWER HELIX.
- MANUFACTURER TO HAVE IN EFFECT INDUSTRY RECOGNIZED WRITTEN QUALITY CONTROL FOR ALL MATERIALS AND MANUFACTURING PROCESSES.
- ALL WELDING TO BE DONE BY WELDERS CERTIFIED UNDER SECTION 5 OF THE AWS CODE D1.1.

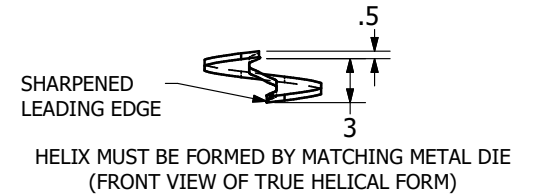

CHANCE®



HUBBELL POWER SYSTEMS, INC.

ROCK-IT™

CONFIDENTIAL: THIS DRAWING AND ITS CONTENTS ARE CONFIDENTIAL AND THE EXCLUSIVE PROPERTY OF HUBBELL POWER SYSTEMS. NO PUBLICATION, DISTRIBUTION, OR COPIES MAY BE MADE WITHOUT THE WRITTEN CONSENT OF HUBBELL POWER SYSTEMS. HUBBELL POWER SYSTEMS UNPUBLISHED ALL RIGHTS RESERVED UNDER THE COPYRIGHT LAWS.

SIZE B	CAT / PART / ASSY NO. SEE TABLE	DWG NO. SA1501488	REV T
DO NOT SCALE THIS DRAWING	DRN BY BLJ	DATE 6/7/19	SHEET 1 OF 2

ROCK-IT™

HELICAL LEAD SECTION

SS200

TORQUE STRENGTH RATING: 16,000 FT-LB
 ULTIMATE CAPACITY* (TENSION/COMPRESSION): 160,000 LB
 *BASED ON A TORQUE FACTOR (Kt=10)
 ULTIMATE TENSION STRENGTH (COUPLING BOLT): 150,000 LB

PART NUMBER	DESCRIPTION	'A'	'B'	'C'	'D'	'E'	'F'	'G'
C1501532	LEAD, SS200, 8/10/12 X 7FT, ROCK-IT™	85.3	81.3	8	10	12	-	2.00
C1501612	LEAD, SS200, 6/8/10 X 5FT, ROCK-IT™	65.6	60.5	6	8	10	-	2.00
C1501836	LEAD, SS200, 6/8/10/12 X 10FT, ROCK-IT™	131	127	6	8	10	12	2.00

SS225

TORQUE STRENGTH RATING: 21,000 FT-LB
 ULTIMATE CAPACITY* (TENSION/COMPRESSION): 210,000 LB
 *BASED ON A TORQUE FACTOR (Kt=10)
 ULTIMATE TENSION STRENGTH (COUPLING BOLT): 200,000 LB

PART NUMBER	DESCRIPTION	'A'	'B'	'C'	'D'	'E'	'F'	'G'
C1501544	LEAD, SS225, 8/10/12 X 7FT, ROCK-IT™	78.7	74.7	8	10	12	-	2.25
C1501715	LEAD, SS225, 6/8/10 X 5FT, ROCK-IT™	65.6	61.6	6	8	10	-	2.25
C1501750	LEAD, SS225, 10/12/14 X 6.5FT, ROCK-IT™	78.7	74.7	10	12	14	-	2.25
C1501756	LEAD, SS225, 6/8/10/12 X 10FT, ROCK-IT™	119	115	6	8	10	12	2.25
C1501757	LEAD, SS225, 8/10/12/14 X 10FT, ROCK-IT™	119	115	8	10	12	14	2.25
C1501868	LEAD, SS225, 8/10/12 X 6.5FT ROCK-IT™	78.7	74.7	8	10	12	-	2.25

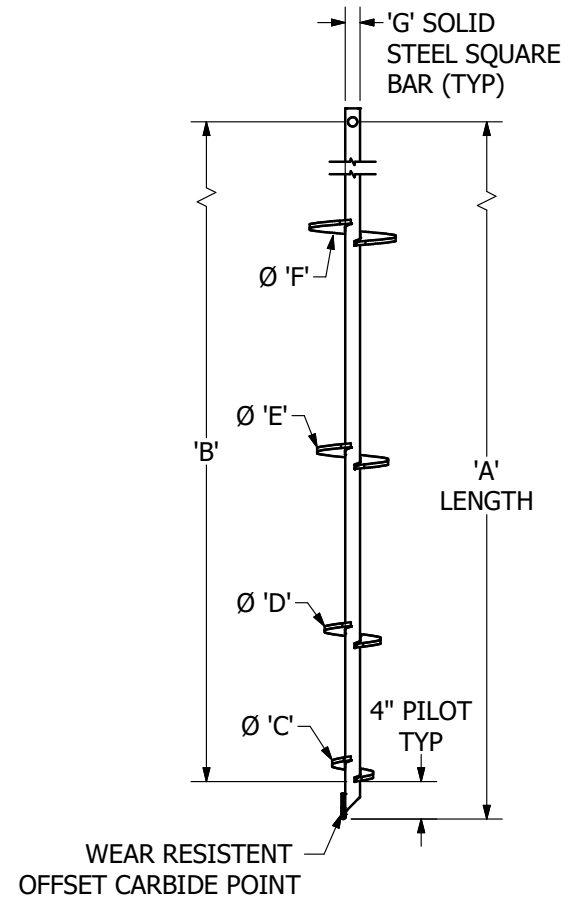
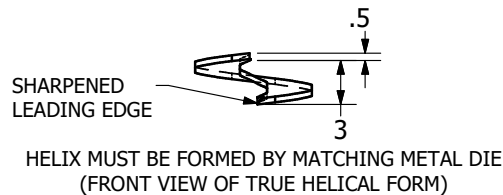

CHANCE ® <small>CONFIDENTIAL: THIS DRAWING AND ITS CONTENTS ARE CONFIDENTIAL AND THE EXCLUSIVE PROPERTY OF HUBBELL POWER SYSTEMS. NO PUBLICATION, DISTRIBUTION, OR COPIES MAY BE MADE WITHOUT THE WRITTEN CONSENT OF HUBBELL POWER SYSTEMS. HUBBELL POWER SYSTEMS UNPUBLISHED ALL RIGHTS RESERVED UNDER THE COPYRIGHT LAWS.</small>	HUBBELL POWER SYSTEMS, INC.		
	TITLE ROCK-IT™		
SIZE B	CAT / PART / ASSY NO. SEE TABLE	DWG NO. SA1501488	REV T
DO NOT SCALE THIS DRAWING	DRN BY BLJ	DATE 6/7/19	SHEET 2 OF 2