

- NOTES-
1. MATERIAL: CAST ALUMINUM BASE AND END FITTING, GALVANIZED STEEL HARDWARE.
 2. 1/2" HARDWARE CONSISTS OF A 2" BOLT, PUSHNUT RETAINER. EXT. TOOTH LOCKWASHER, SPRING LOCKWASHER, AND HEX NUT.
 3. SPACER BAR INCLUDED ON CATALOG NUMBERS WITH A "-CSB" SUFFIX ONLY (EX. 1SBM12CSB).
 4. SEE CHART FOR ULTIMATE VERTICAL, LONGITUDINAL, AND TRANSVERSE LOAD RATINGS

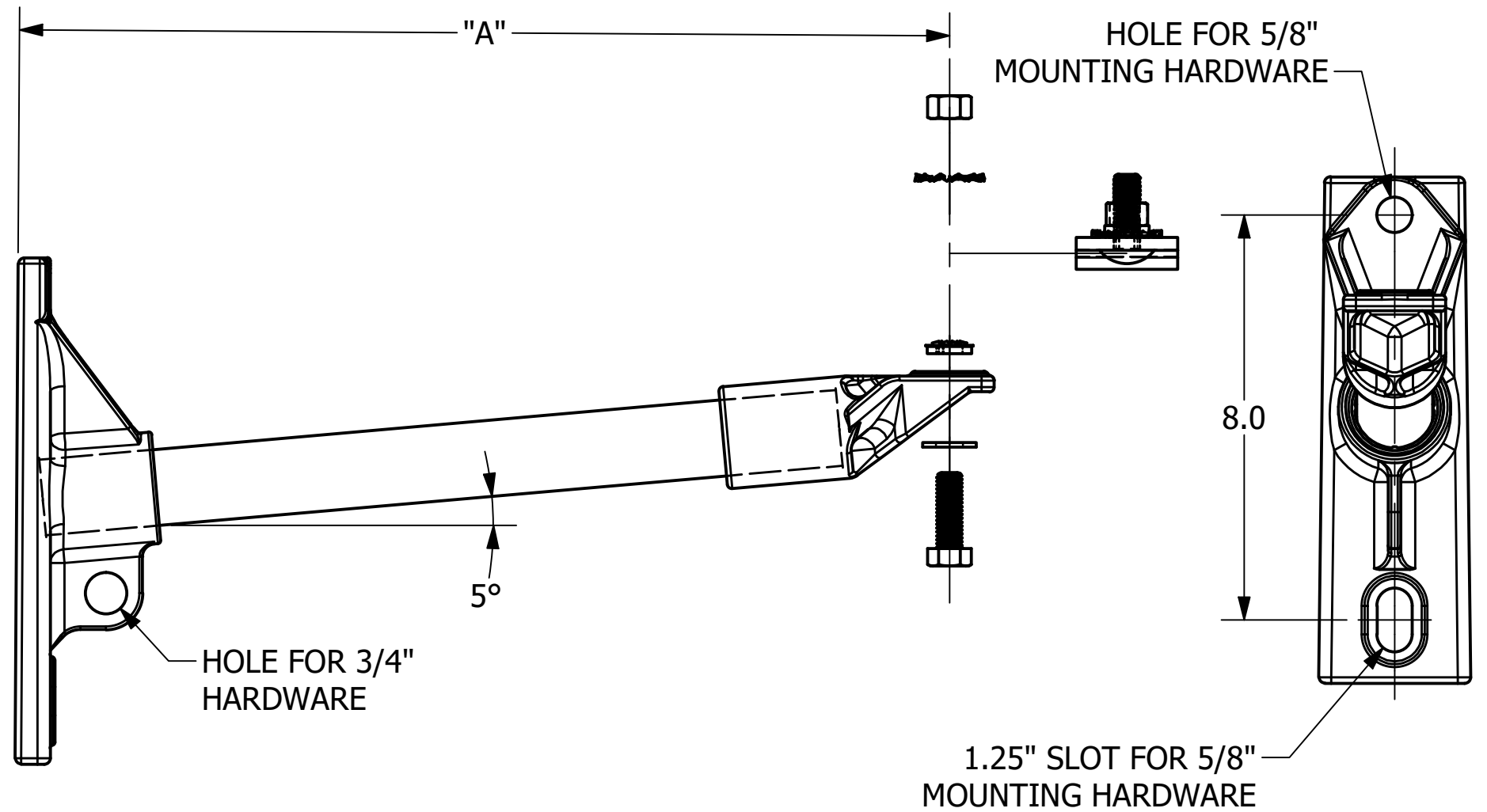

CATALOG NUMBER	"A"	VERTICAL (NOTE-4)	LONGITUDINAL (NOTE-4)	TRANSVERSE (NOTE-4)
1SBM12C	12	1200 LBS	900 LBS	1500 LBS
1SBM15C	15	1800 LBS	800 LBS	1500 LBS
1SBM18C	18	1500 LBS	700 LBS	1500 LBS
1SBM21C	21	2100 LBS	600 LBS	1500 LBS
1SBM12CB	12	1200 LBS	900 LBS	1500 LBS
1SBM15CB	15	1800 LBS	800 LBS	1500 LBS
1SBM18CB	18	1500 LBS	700 LBS	1500 LBS
1SBM21CB	21	2100 LBS	600 LBS	1500 LBS
1SBM12CSB	12	1200 LBS	900 LBS	1500 LBS
1SBM15CSB	15	1800 LBS	800 LBS	1500 LBS
1SBM18CSB	18	1500 LBS	700 LBS	1500 LBS
1SBM21CSB	21	2100 LBS	600 LBS	1500 LBS

<h1>CHANCE[®]</h1>	HUBBELL POWER SYSTEMS, INC.			
	STANDOFF, CUTOUT/ARRESTER 1-PHASE			
CONFIDENTIAL: THIS DRAWING AND ITS CONTENTS ARE CONFIDENTIAL AND THE EXCLUSIVE PROPERTY OF HUBBELL POWER SYSTEMS. NO PUBLICATION, DISTRIBUTION, OR COPIES MAY BE MADE WITHOUT THE WRITTEN CONSENT OF HUBBELL POWER SYSTEMS. HUBBELL POWER SYSTEMS UNPUBLISHED ALL RIGHTS RESERVED UNDER THE COPYRIGHT LAWS.	SIZE B	CAT / PART / ASSY NO. SEE CHART	DWG NO. SA1SBMXXCB	REV A
DO NOT SCALE THIS DRAWING	DRN BY HOEK	DATE 3/22/22	SHEET 1 OF 1	