

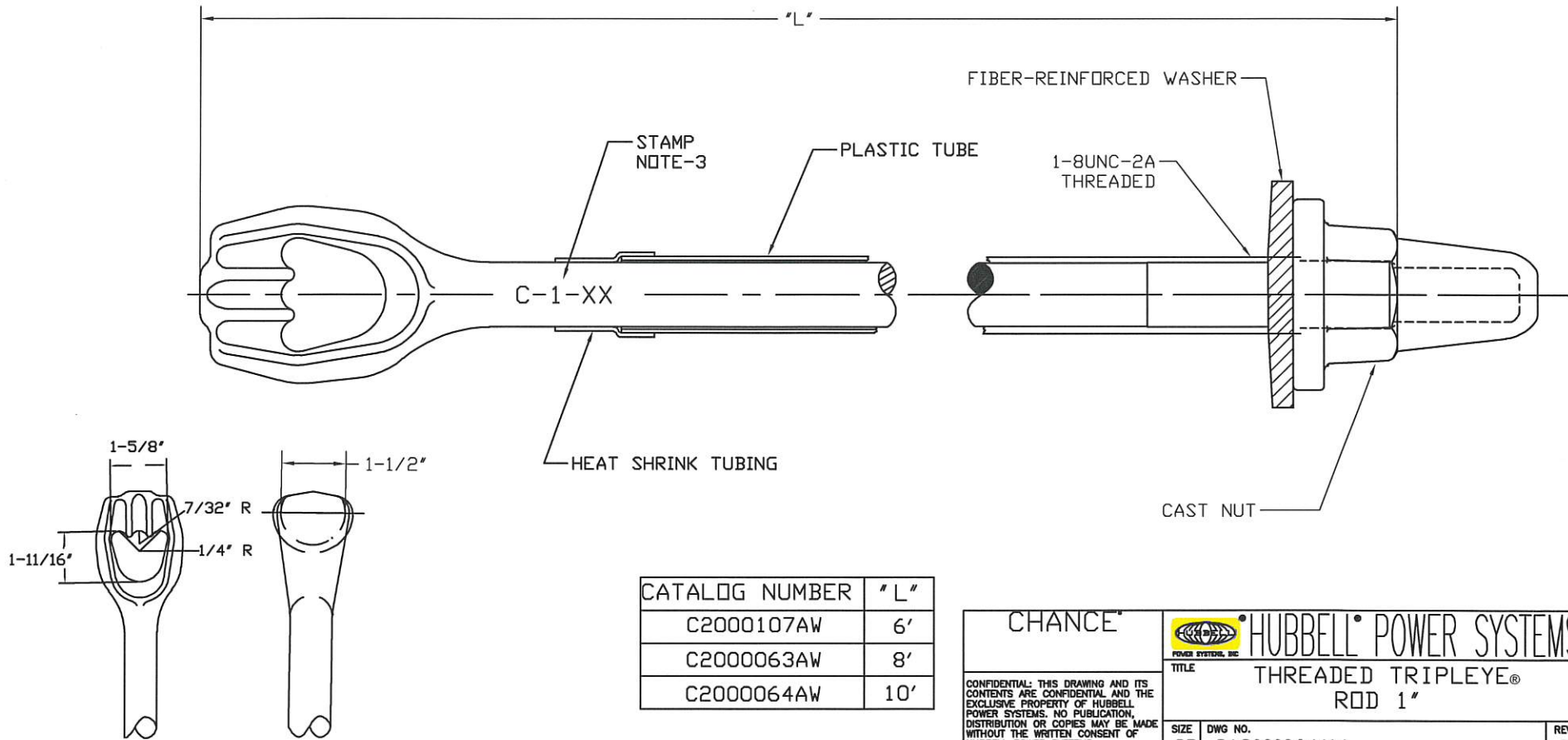

- NOTES-
1. MAT'L: STEEL, HOTDIP GALV. PER ASTM A153 (LATEST REV)
 2. FINISH: BLACK ASPHALT COATING.
 3. XX DENOTES THE LENGTH STAMP OF THE ROD, SEE "L" FOR LENGTHS.
 4. ADD USA SUFFIX TO CATALOG NUMBER FOR BUY AMERICA ITEMS. PURCHASERS OF BUY AMERICA ITEMS WILL BE PROVIDED A DATED CERTIFICATE OF COMPLIANCE TO SPECIFIC BUY AMERICA PROVISIONS IF REQUESTED AT THE TIME OF ORDER. CONTACT HUBBELL POWER SYSTEMS CUSTOMER SERVICE FOR DETAILS.



CATALOG NUMBER	"L"
C2000107AW	6'
C2000063AW	8'
C2000064AW	10'

CHANCE		 HUBBELL POWER SYSTEMS	
<small>CONFIDENTIAL: THIS DRAWING AND ITS CONTENTS ARE CONFIDENTIAL AND THE EXCLUSIVE PROPERTY OF HUBBELL POWER SYSTEMS. NO PUBLICATION, DISTRIBUTION OR COPIES MAY BE MADE WITHOUT THE WRITTEN CONSENT OF HUBBELL POWER SYSTEMS. HUBBELL POWER SYSTEMS UNPUBLISHED ALL RIGHTS RESERVED UNDER THE COPYRIGHT LAWS.</small>		TITLE THREADED TRIPLEYE® ROD 1"	
SIZE	DWG NO.	REV	
SB	SA2000064AW	B	
DO NOT SCALE THIS DRAWING	DRN BY ME:B	DATE 12/15/15	SHEET 1/1