

* * NOTES * *

1. FINISH:

C2050407: ELECTRO-PLATED ZINC

C2050408: ELECTRO-PLATED ZINC

C2050556: HOT DIP OR MECHANICALLY GALVANIZED

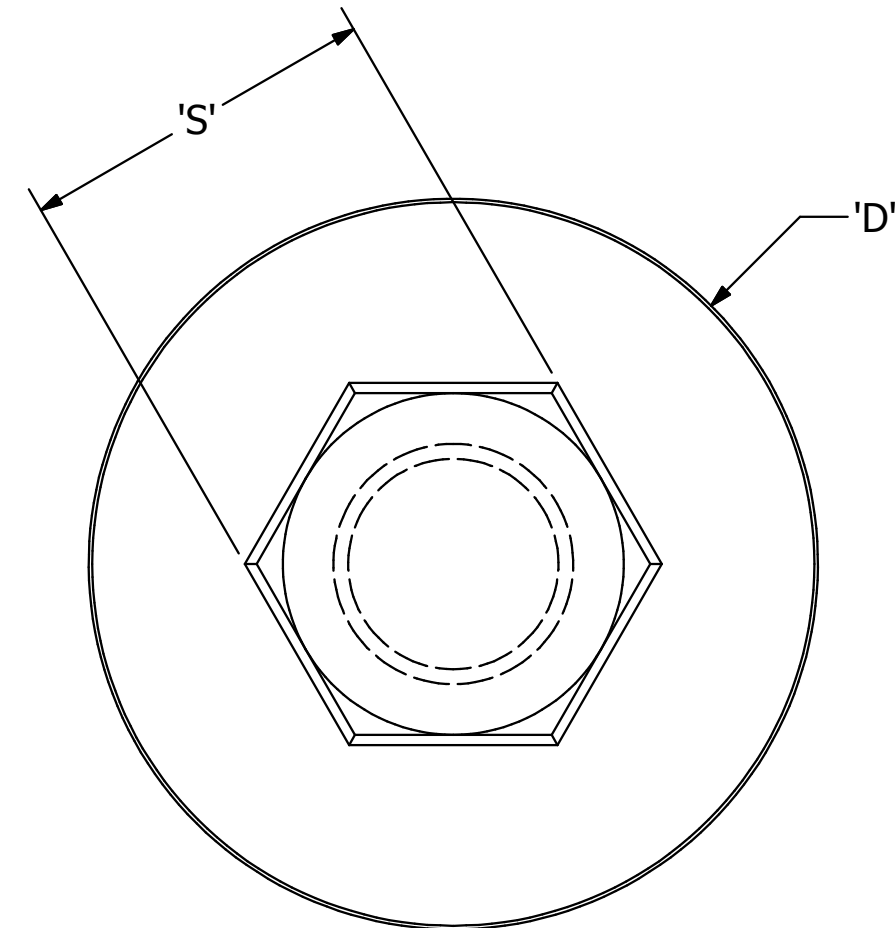
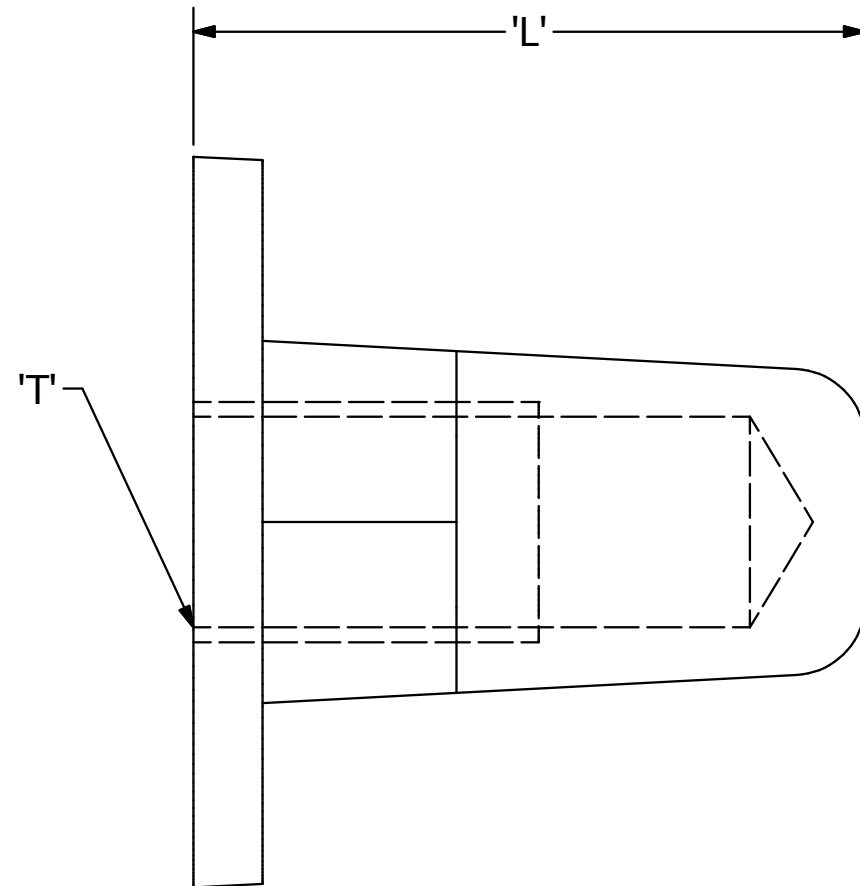

PART NO.	DESCRIPTION	'T'	'S'	'L'	'D'
C2050407	ANCHOR, DISK NUT: 3/4in.	0828-10 UNS	1.35	2.80	2.85
C2050408	ANCHOR, DISK NUT: 1in.	1.021-8 UNS	1.75	3.50	2.85
C2050590	NUT, DISK ANCHOR, 1-1/4"	1.271-7 UNS	1.88	3.50	3.80

<h1>CHANCE®</h1>	HUBBELL POWER SYSTEMS, INC.			
	TITLE <h2>WASHER NUT</h2>			
CONFIDENTIAL: THIS DRAWING AND ITS CONTENTS ARE CONFIDENTIAL AND THE EXCLUSIVE PROPERTY OF HUBBELL POWER SYSTEMS. NO PUBLICATION, DISTRIBUTION, OR COPIES MAY BE MADE WITHOUT THE WRITTEN CONSENT OF HUBBELL POWER SYSTEMS. HUBBELL POWER SYSTEMS UNPUBLISHED ALL RIGHTS RESERVED UNDER THE COPYRIGHT LAWS.	SIZE B	CAT / PART / ASSY NO. SEE CHART	DWG NO. SA2050408	REV C
	DO NOT SCALE THIS DRAWING	DRN BY JCA	DATE 2/25/09	SHEET 1 OF 1