

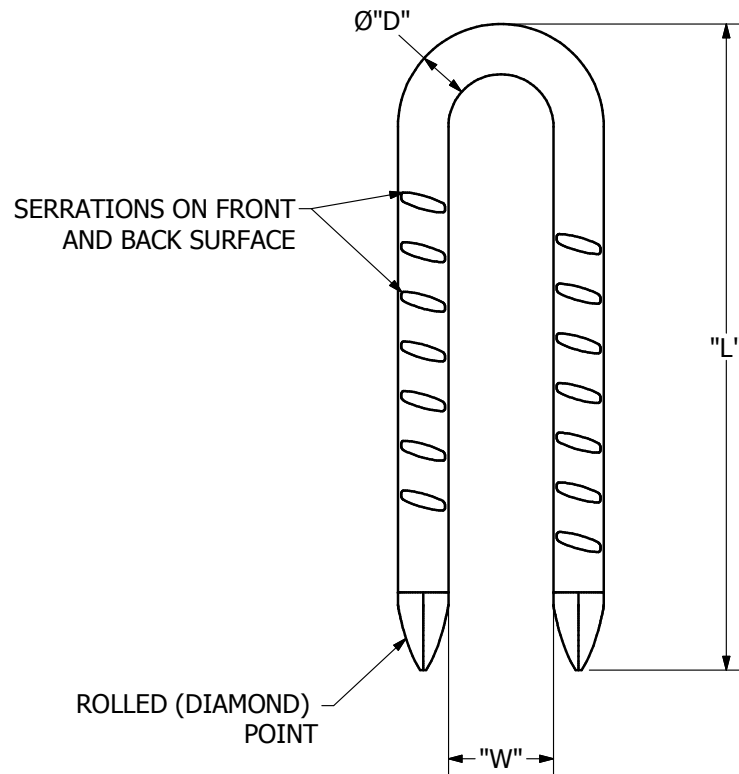

# NOTES

1. MATERIAL: STEEL WIRE
2. FINISH: COPPER COATED



CATALOG #	"L"	"W"	"D"
PSC2050580	2"	1/2"	0.162"
PSC2050581	3"	1-1/16"	0.25"

<b>CHANCE®</b>		 <b>HUBBELL POWER SYSTEMS, Inc.</b>	
<small>CONFIDENTIAL: THIS DRAWING AND ITS CONTENTS ARE CONFIDENTIAL AND THE EXCLUSIVE PROPERTY OF HUBBELL POWER SYSTEMS. NO PUBLICATION, DISTRIBUTION OR COPIES MAY BE MADE WITHOUT THE WRITTEN CONSENT OF HUBBELL POWER SYSTEMS. HUBBELL POWER SYSTEMS UNPUBLISHED ALL RIGHTS RESERVED UNDER THE COPYRIGHT LAWS.</small>		<b>SERRATED STAPLE</b>	
		<small>SIZE</small> <b>SB SEE CHART</b>	<small>DWG NO.</small> <b>SA205-0580</b>
		<small>DO NOT SCALE THIS DRAWING</small>	<small>DRN BY WILSON</small>
		<small>DATE</small> 08/01/14	<small>SHEET</small> 1 OF 1