

CATALOG NUMBER	DESCRIPTION
PSC2080579	END WALL MOUNTED SWINGARM
PSC2060260	SIDE WALL MOUNTED SWINGARM

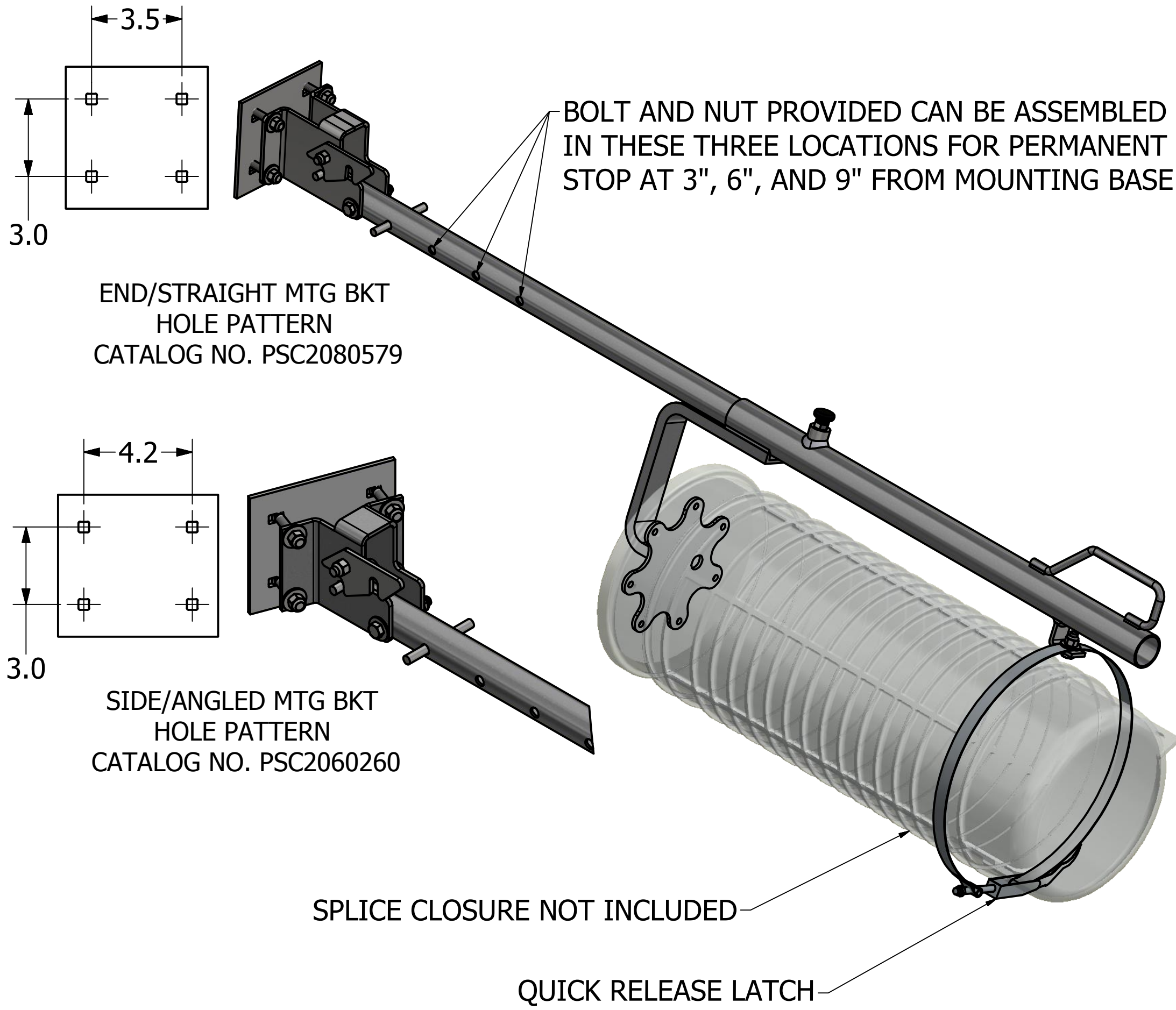

-NOTES-

1. MATERIAL: STEEL
2. FINISH: HOT DIP GALVANIZE PER ASTM A153.
3. LCPE MOUNTING PLATE ACCEPTS PLP COYOTE 9.5" X 28" DOME.
4. HARDWARE INCLUDED FOR BRACKET MOUNTING .
5. SWINGARM TELESCOPES 23".
6. SWINGARM ROTATES 360° IN EITHER DIRECTION.
7. FITS 3 LCPE ASSEMBLIES IN A 36" X 60" ENCLOSURE.
8. MOUNTS DIRECTLY TO HPS TORSION COVER.
-NO DRILLING REQUIRED-
9. REFERENCE INSTALLATION INSTRUCTION TD06022E.

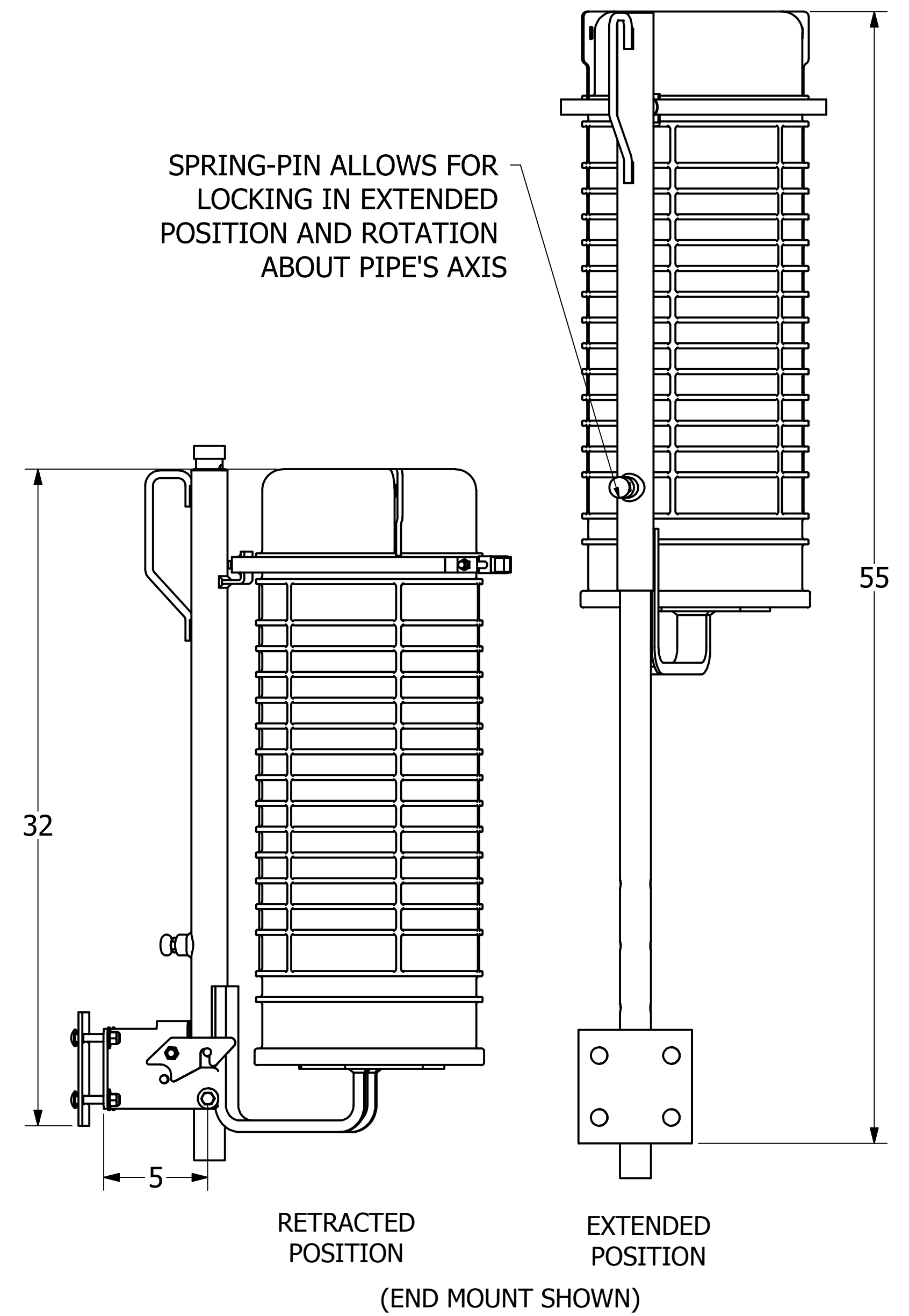

CHANCE [®]	HUBBELL [®] HUBBELL POWER SYSTEMS, INC. <small>POWER SYSTEMS, INC.</small>			
	TITLE LCPE SWINGARM ASSEMBLY			
CONFIDENTIAL: THIS DRAWING AND ITS CONTENTS ARE CONFIDENTIAL AND THE EXCLUSIVE PROPERTY OF HUBBELL POWER SYSTEMS. NO PUBLICATION, DISTRIBUTION, OR COPIES MAY BE MADE WITHOUT THE WRITTEN CONSENT OF HUBBELL POWER SYSTEMS. HUBBELL POWER SYSTEMS UNPUBLISHED ALL RIGHTS RESERVED UNDER THE COPYRIGHT LAWS.	SIZE C	CAT / PART / ASSY NO. SEE TABLE	DWG NO. SA2060260	REV A
	DO NOT SCALE THIS DRAWING	DRN BY TLB	DATE 4/23/19	SHEET 1 OF 1