

- NOTES -

1. MATERIAL: HOT DIP GALVANIZED STEEL
2. CATALOG NUMBERS SHIPPED UNASSEMBLED

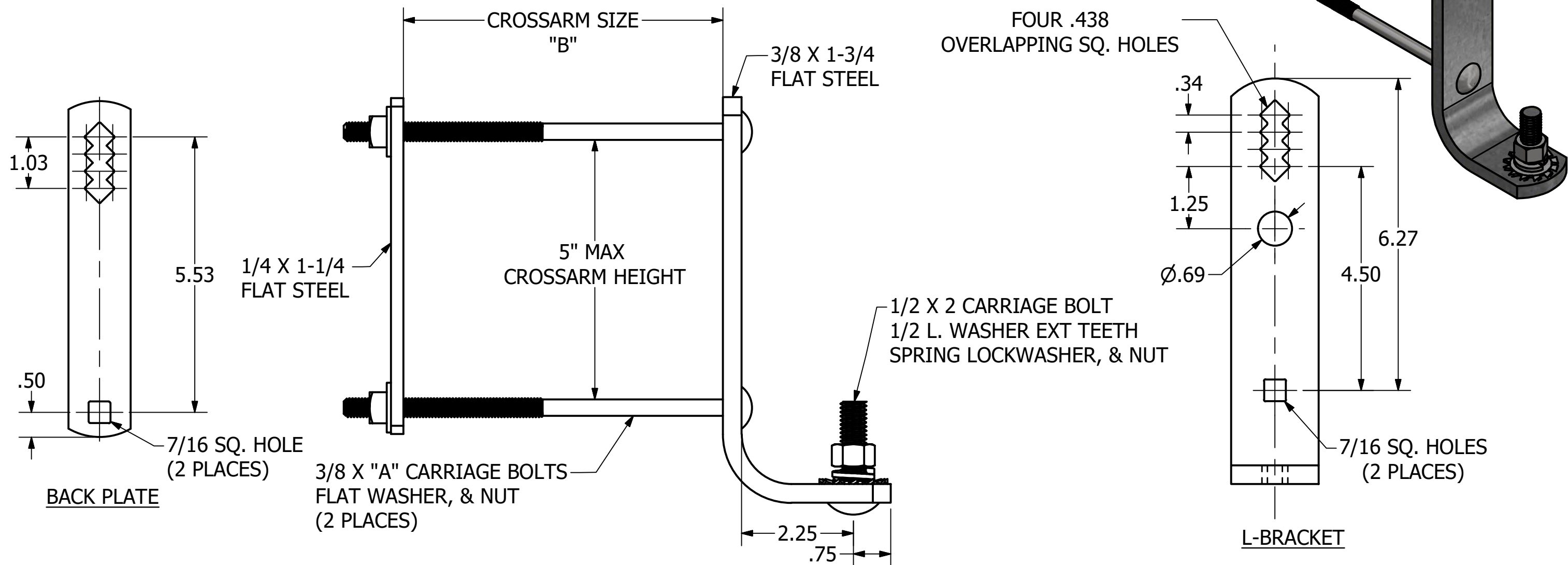

CATALOG NUMBER	"A"	"B"
C2060283	5"	1-1/8" TO 3-3/4"
PSC2061154	8"	3-1/4" TO 6-3/4"

CHANCE [®]		HUBBELL [®] HUBBELL POWER SYSTEMS, INC.	
CONFIDENTIAL: THIS DRAWING AND ITS CONTENTS ARE CONFIDENTIAL AND THE EXCLUSIVE PROPERTY OF HUBBELL POWER SYSTEMS. NO PUBLICATION, DISTRIBUTION, OR COPIES MAY BE MADE WITHOUT THE WRITTEN CONSENT OF HUBBELL POWER SYSTEMS. HUBBELL POWER SYSTEMS UNPUBLISHED ALL RIGHTS RESERVED UNDER THE COPYRIGHT LAWS.			
TITLE CUTOUT ARRESTER BRACKET			
SIZE B	CAT / PART / ASSY NO. SEE CHART	DWG NO. SA2060283	REV F
DO NOT SCALE THIS DRAWING	DRN BY TBT	DATE 6/13/19	SHEET 1 OF 1