

=NOTES=

1. MATERIAL: HOT ROLLED STEEL PER ASTM A-36.
2. HOT DIP GALVANIZE PER ASTM A-153 (LATEST REVISION).

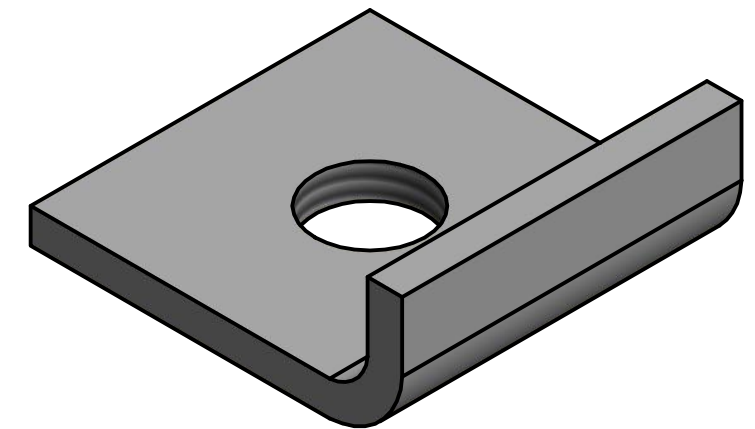
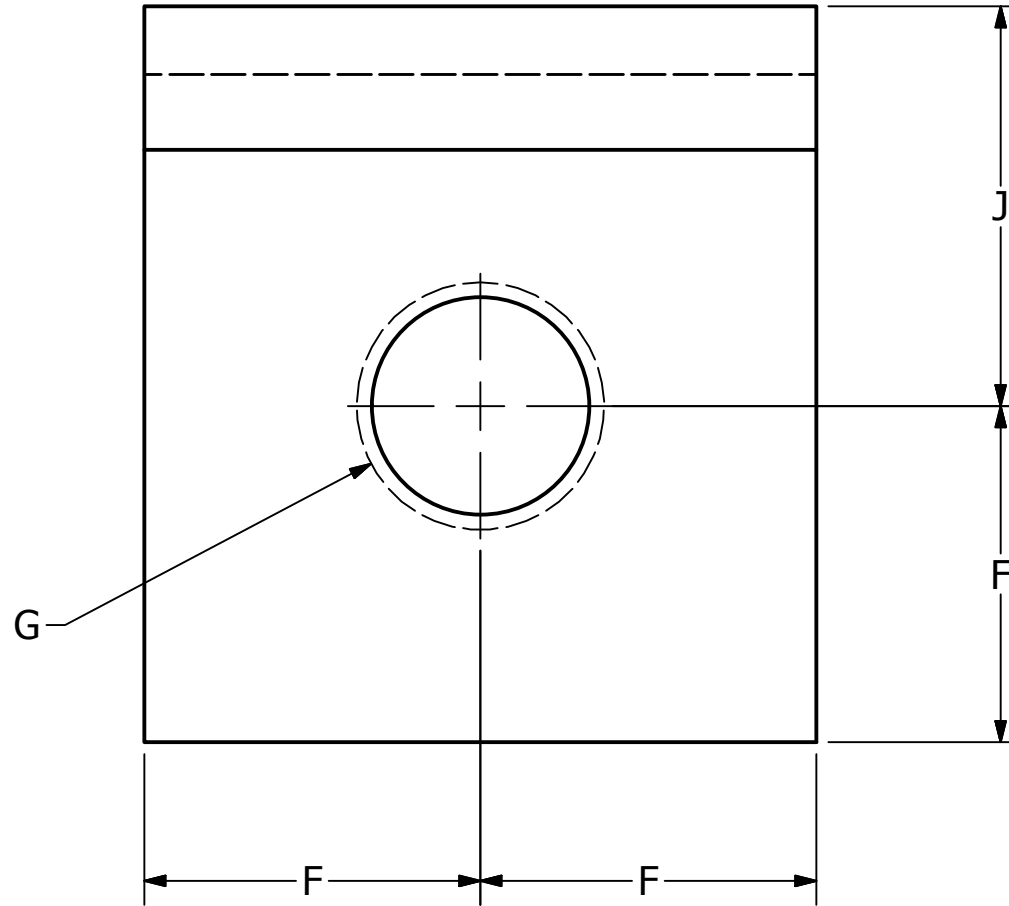
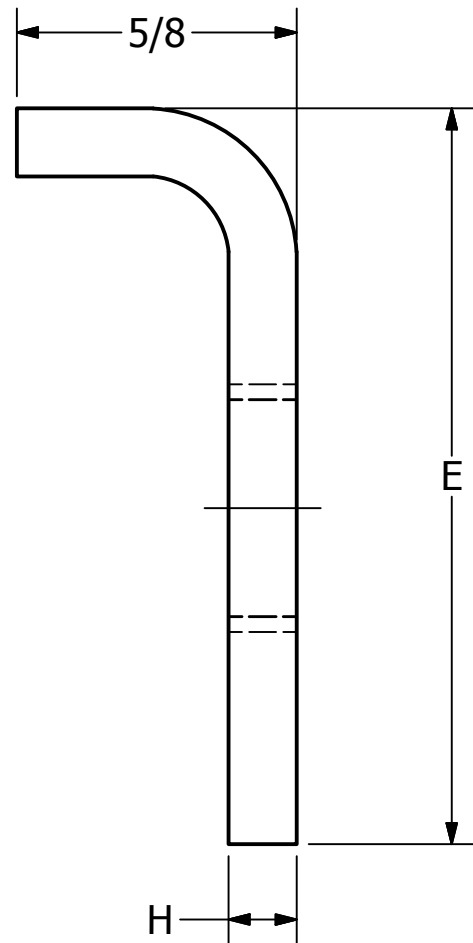

CATALOG NO.	PG&E CODE	BOLT	"E"	"F"	"G"	"H"	"J"
T2060402	18-8167	5/8	2-3/16"	1"	5/8-11UNC-2B	7 GA.	1-3/16"
T2060403	18-8168	3/4	3"	1-1/2"	3/4-10UNC-2B	1/4"	1-1/2"

CHANCE [®]	HUBBELL POWER SYSTEMS, INC.			
	TITLE LIP WASHER			
CONFIDENTIAL: THIS DRAWING AND ITS CONTENTS ARE CONFIDENTIAL AND THE EXCLUSIVE PROPERTY OF HUBBELL POWER SYSTEMS. NO PUBLICATION, DISTRIBUTION, OR COPIES MAY BE MADE WITHOUT THE WRITTEN CONSENT OF HUBBELL POWER SYSTEMS. HUBBELL POWER SYSTEMS UNPUBLISHED ALL RIGHTS RESERVED UNDER THE COPYRIGHT LAWS.	SIZE B	CAT / PART / ASSY NO. SEE TABLE	DWG NO. SA2060402	REV B
DO NOT SCALE THIS DRAWING	DRN BY TLB	DATE 3/7/19	SHEET 1 OF 1	