

-NOTES-

1. SUSPENSION CLAMP FOR JACKETED STRANDS (FIGURE 8 CABLE), 1/4" and 3/8" BARE MESSENGER WIRE. SERPENTINE GROOVES IN THE MOUNTING PLATES PROVIDE SUPERIOR HOLDING STRENGTH OF INSULATED MESSENGER WIRE.
2. ACCOMODATES 5/8" DIAMETER POLE MOUNTING BOLT.
3. SUPPLIED WITH (2) 5/8" TRACK BOLTS/SQUARE NUTS.
4. DUCTILE IRON PER ASTM A536, GALVANIZED PER ASTM A153.
5. MEETS TELECORDIA GR-3174-CORE; BELLCORE SPECIFICATION AT-8261.

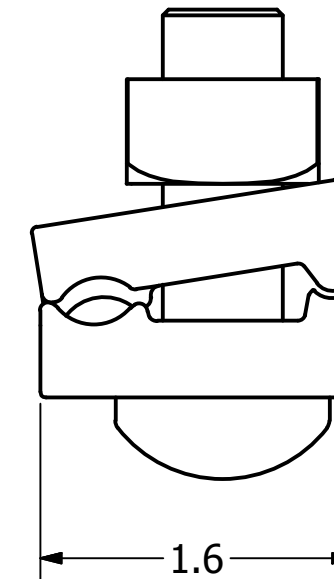
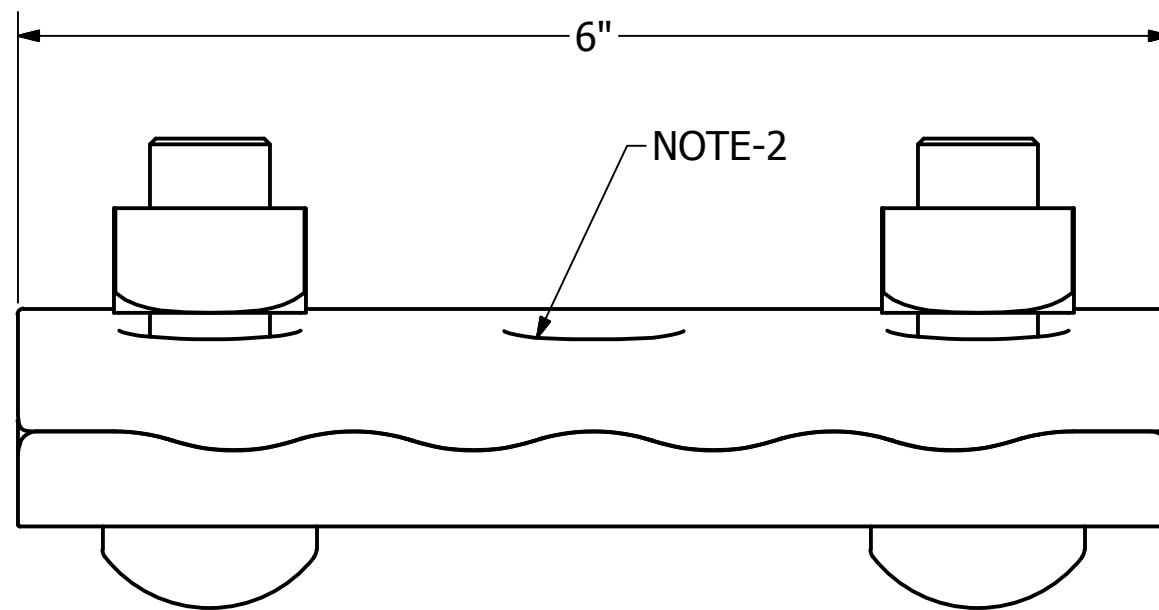
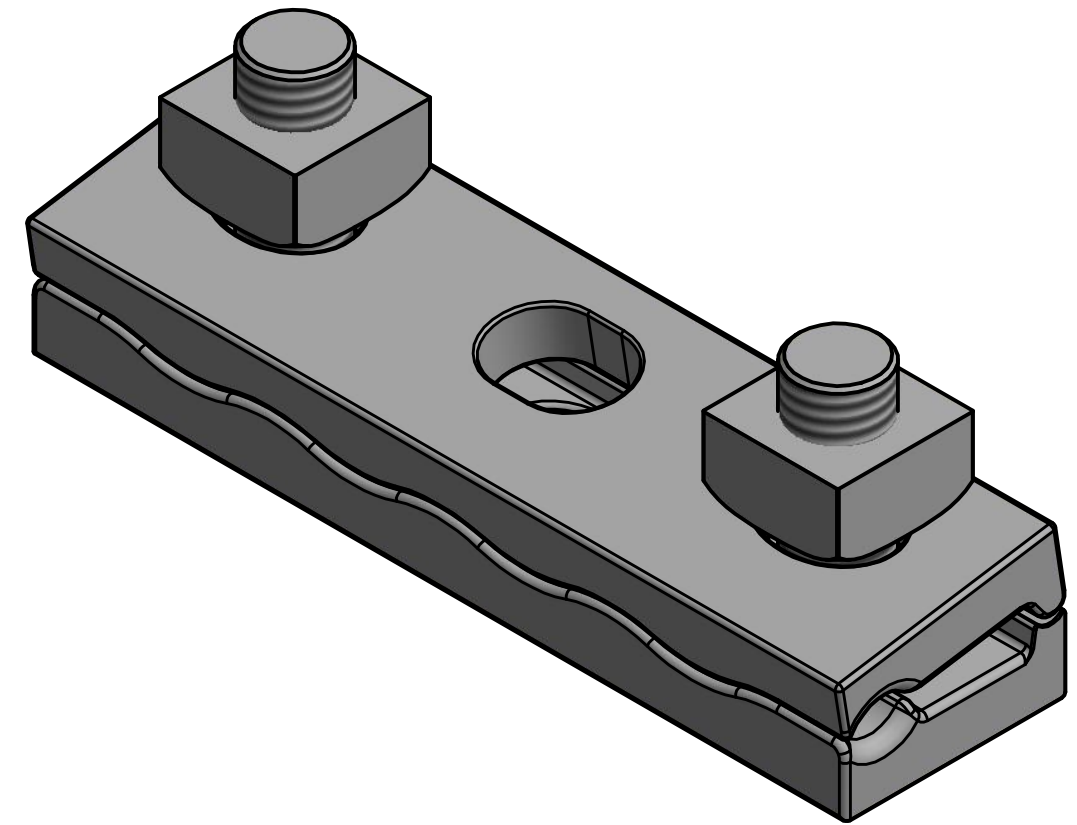

CATALOG NO.: PSC2080296

CHANCE [®]	HUBBELL [®] POWER SYSTEMS, INC.			
	TITLE C CABLE CLAMP			
CONFIDENTIAL: THIS DRAWING AND ITS CONTENTS ARE CONFIDENTIAL AND THE EXCLUSIVE PROPERTY OF HUBBELL POWER SYSTEMS. NO PUBLICATION, DISTRIBUTION, OR COPIES MAY BE MADE WITHOUT THE WRITTEN CONSENT OF HUBBELL POWER SYSTEMS. HUBBELL POWER SYSTEMS UNPUBLISHED ALL RIGHTS RESERVED UNDER THE COPYRIGHT LAWS.	SIZE B	CAT / PART / ASSY NO. PSC2080296	DWG NO. SA2080296	REV -
	DO NOT SCALE THIS DRAWING	DRN BY MTH	DATE 9/16/16	SHEET 1 OF 1