

- NOTES-
1. SECURES MID-SPAN MESSENGER STRANDS CROSSING PERPENDICULARLY TO EACH OTHER TO PREVENT ABRASION.
 2. ACCOMMODATES STRANDS RANGING FROM 1/4" TO 3/8".
 3. SUPPLIED WITH (2) 1/2" BOLTS/SQUARE NUTS.
 4. DUCTILE IRON PER ASTM A536, GALVANIZED PER ASTM A153.

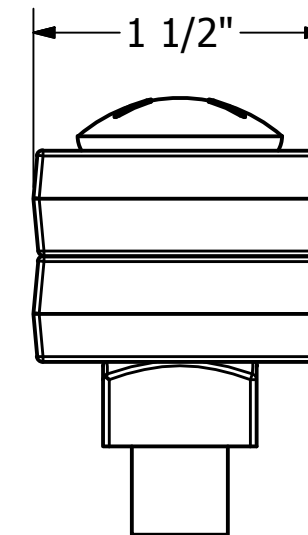
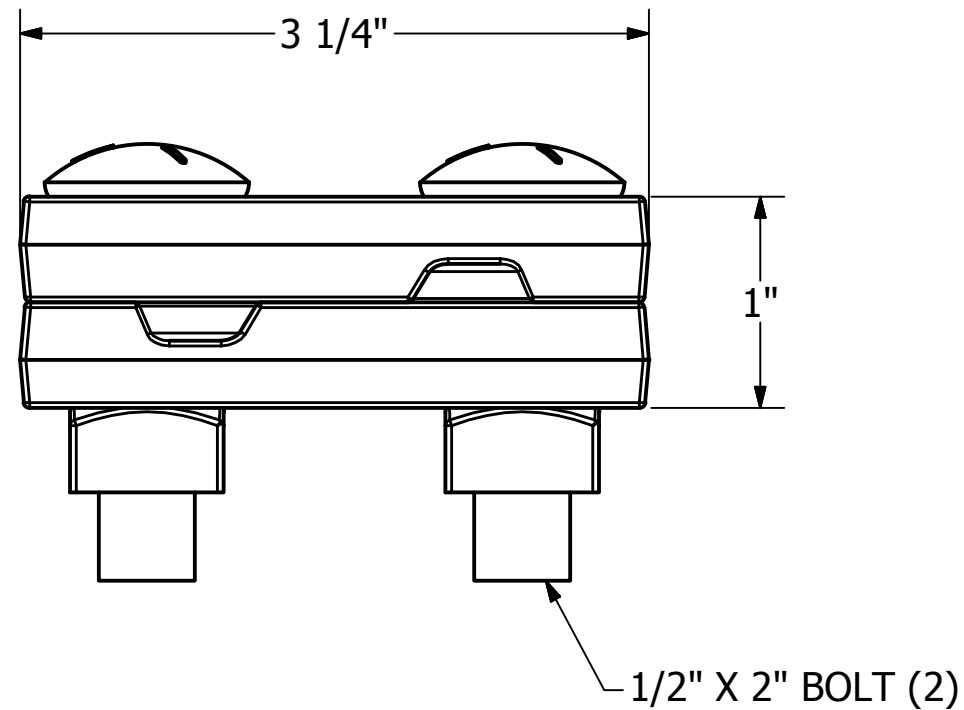
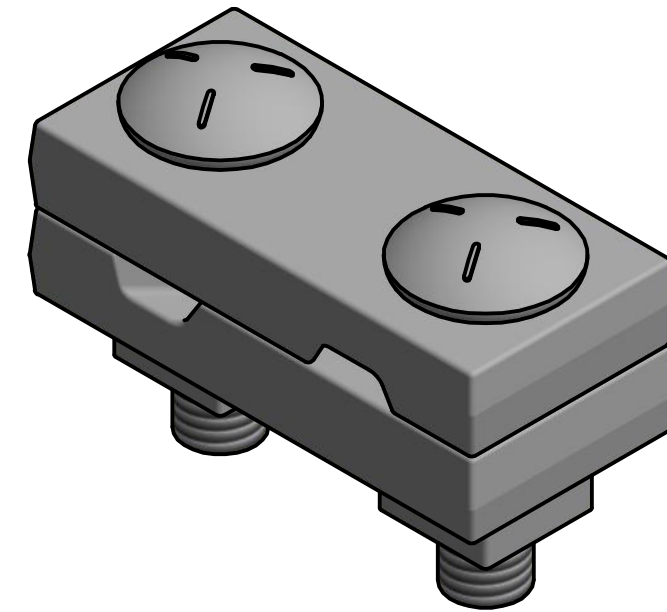

CATALOG NO.: PSC2080480

CHANCE [®]	HUBBELL POWER SYSTEMS, INC.			
	TITLE CROSSOVER CLAMP ASSEMBLY			
CONFIDENTIAL: THIS DRAWING AND ITS CONTENTS ARE CONFIDENTIAL AND THE EXCLUSIVE PROPERTY OF HUBBELL POWER SYSTEMS. NO PUBLICATION, DISTRIBUTION, OR COPIES MAY BE MADE WITHOUT THE WRITTEN CONSENT OF HUBBELL POWER SYSTEMS. HUBBELL POWER SYSTEMS UNPUBLISHED ALL RIGHTS RESERVED UNDER THE COPYRIGHT LAWS.	SIZE B	CAT / PART / ASSY NO. PSC2080480	DWG NO. SA2080480	REV --
	DO NOT SCALE THIS DRAWING	DRN BY MTH	DATE 9/19/16	SHEET 1 OF 1