

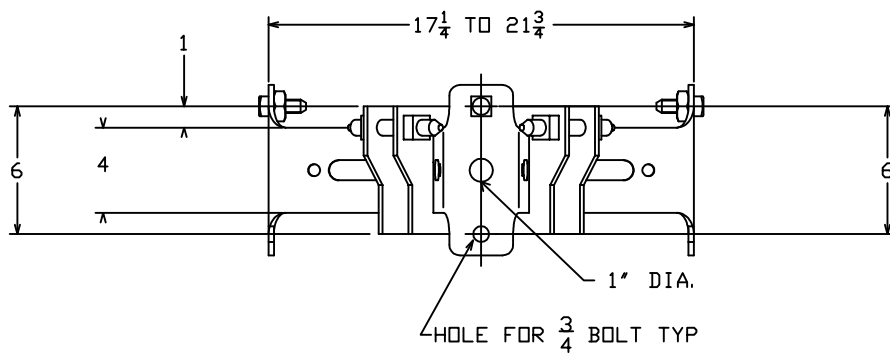

==NOTE==

1. MAT'L: STEEL, HOT DIP GALVANIZED PER ASTM A153 LATEST REVISION.
2. FITS POLE FROM 6 INCHES TO 10-1/2 INCHES IN DIAMETER.

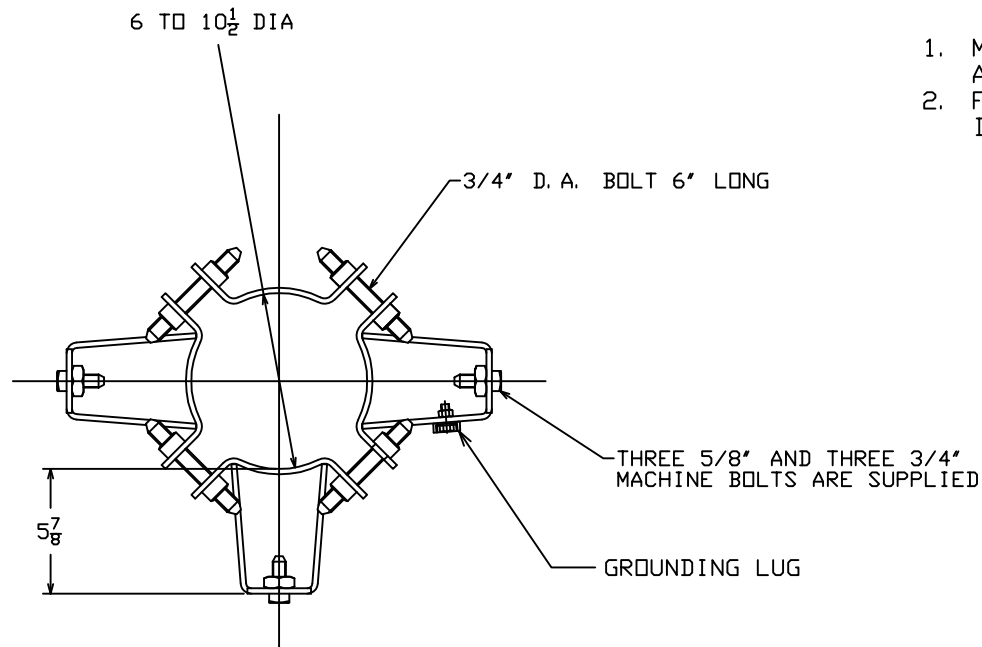

CAT. NO. PSC2110076

CHANCE [®] TOLERANCE CHART		 HUBBELL[®] POWER SYSTEMS	
<small>CONFIDENTIAL: THIS DRAWING AND ITS CONTENTS ARE CONFIDENTIAL AND THE EXCLUSIVE PROPERTY OF HUBBELL POWER SYSTEMS. NO PUBLICATION, DISTRIBUTION OR COPIES MAY BE MADE WITHOUT THE WRITTEN CONSENT OF HUBBELL POWER SYSTEMS. HUBBELL POWER SYSTEMS UNPUBLISHED ALL RIGHTS RESERVED UNDER THE COPYRIGHT LAWS.</small>		<small>TITLE</small> TRANSFORMER MOUNTING BRACKET	
		<small>SIZE</small> SB SA2110076	<small>CAT / PART / ASSY NO.</small> PSC2110076
<small>DO NOT SCALE THIS DRAWING</small>	<small>DRN BY</small> HORVATH	<small>DATE</small> 5/26/2015	<small>SHEET 1 OF</small> 1