

-NOTES-

1. FOOT CONTROL FOR SERIES 90 HOISTS.
2. FOR 115- AND 230-VOLT AC DRIVE.
3. 25' LONG WITH SWITCH LOCATED IN THE MIDDLE.
4. WEIGHT: 3 LB.

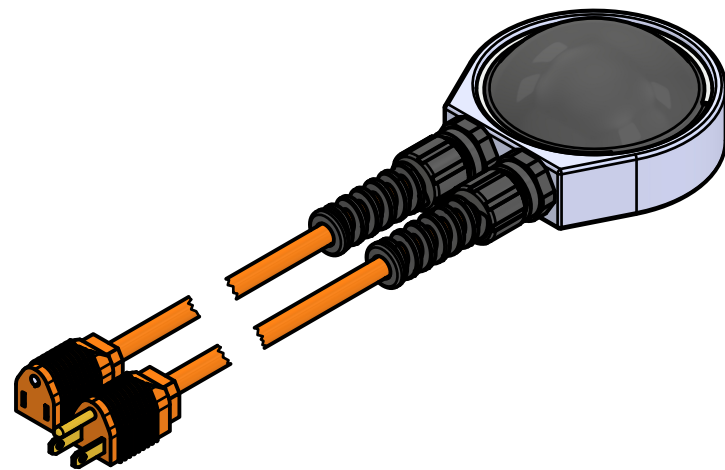
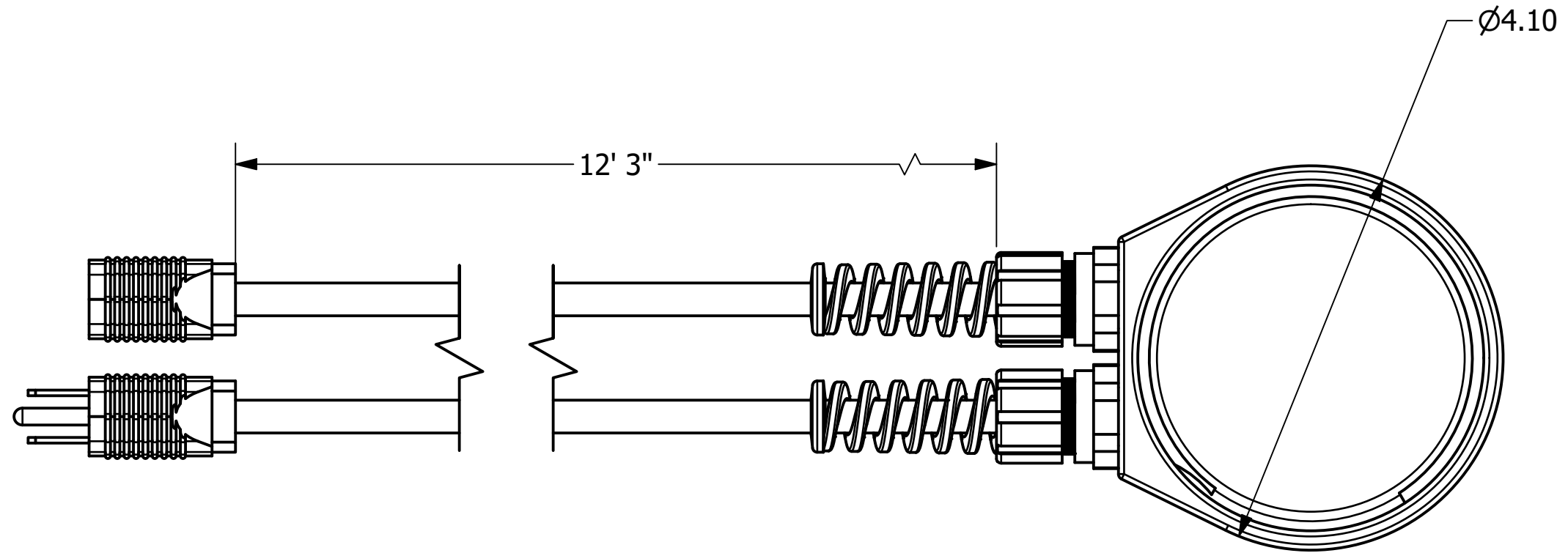

<h1>CHANCE[®]</h1>	HUBBELL POWER SYSTEMS, INC.			
	<small>POWER SYSTEMS, INC.</small> TITLE FOOT SWITCH			
CONFIDENTIAL: THIS DRAWING AND ITS CONTENTS ARE CONFIDENTIAL AND THE EXCLUSIVE PROPERTY OF HUBBELL POWER SYSTEMS. NO PUBLICATION, DISTRIBUTION, OR COPIES MAY BE MADE WITHOUT THE WRITTEN CONSENT OF HUBBELL POWER SYSTEMS. HUBBELL POWER SYSTEMS UNPUBLISHED ALL RIGHTS RESERVED UNDER THE COPYRIGHT LAWS.	SIZE B	CAT / PART / ASSY NO. C417-0337	DWG NO. SA417-0337	REV A
	DO NOT SCALE THIS DRAWING	DRN BY IMJ	DATE 10/25/2023	SHEET 1 OF 1