

-NOTES-

- MATERIAL: STEEL, HOT DIP GALVANIZED PER ASTM A153 (LATEST REVISION)

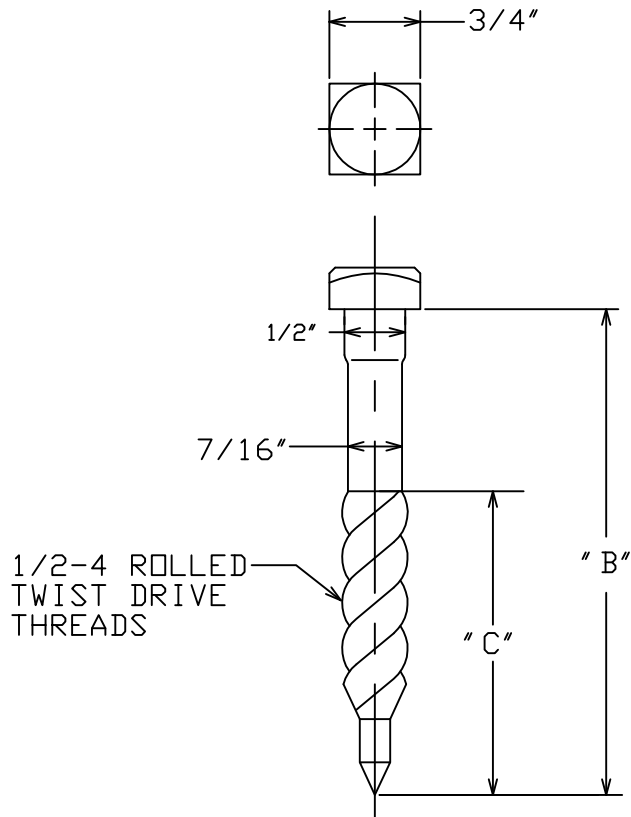

CATALOG NUMBER	DESCRIPTION	"B"	"C"
PSC2050602	3" TWIST DRIVE LAG SCREW WITH PILOT POINT	3	2.250
508500	4" TWIST DRIVE LAG SCREW WITH PILOT POINT	4	2.620

CHANCE TOLERANCE CHART X ± .060 FRAC ±1/16 ANGLES ±2° XX ± .030 ADD DRAFT (UNLESS NOTED) XXX ± .005 CASTING ± FORGINGS 7°		HUBBELL POWER SYSTEMS POWER SYSTEMS, INC.	
CONFIDENTIAL: THIS DRAWING AND ITS CONTENTS ARE CONFIDENTIAL AND THE EXCLUSIVE PROPERTY OF HUBBELL POWER SYSTEMS. NO PUBLICATION, DISTRIBUTION OR COPIES MAY BE MADE WITHOUT THE WRITTEN CONSENT OF HUBBELL POWER SYSTEMS. HUBBELL POWER SYSTEMS UNPUBLISHED ALL RIGHTS RESERVED UNDER THE COPYRIGHT LAWS.			
TITLE: TWIST DRIVE LAG SCREW WITH PILOT POINT			
SIZE	DWG NO.	CAT / PART / ASSY NO.	REV
B	SA508500	SEE CHART	A
DO NOT SCALE THIS DRAWING	DRN BY MARTIN	DATE 3/1/01	SHEET 1 OF 1