

MANUFACTURER'S  
ID

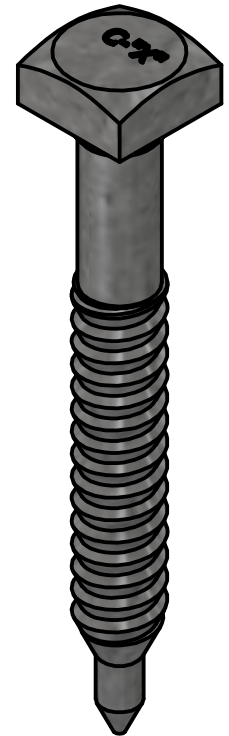
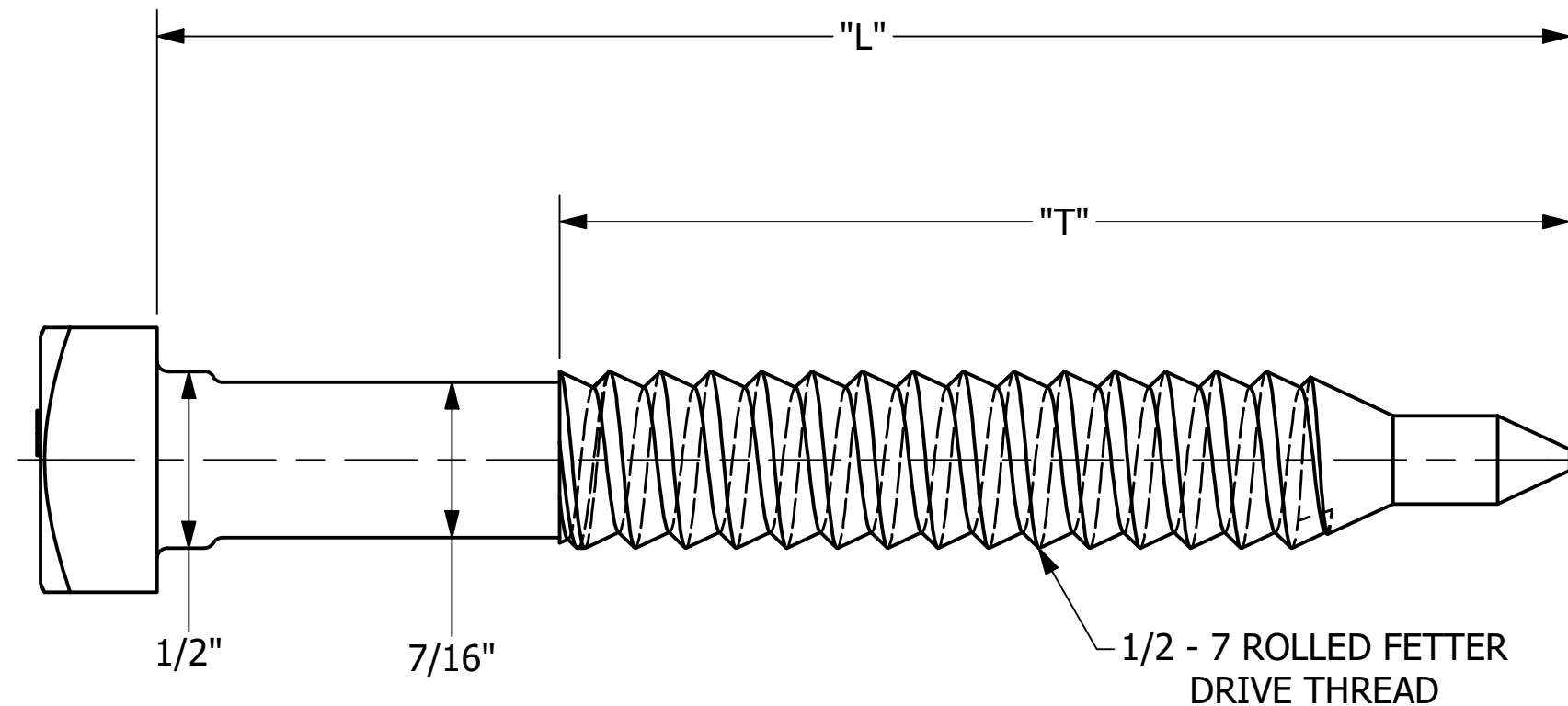
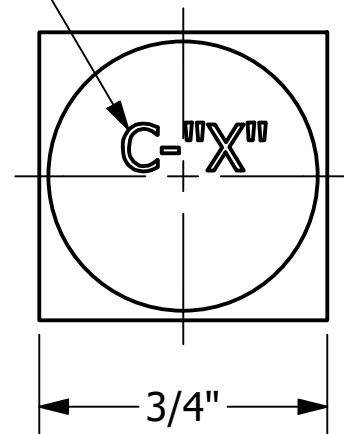

- NOTES -

1. HOT DIP GALVANIZE PER ASTM A153 (LATEST REV).
2. CATALOG NUMBERS WITH A "USA" SUFFIX HAVE ALL COMPONENTS MELTS AND MANUFACTURED IN THE USA.
3. STRENGTH AND PERFORMANCE REQUIREMENTS PER IEEE C135.3.

CATALOG NO.	USA PART NO.	"L"	"T"
508753	508453USA	3"	2.25"
508754	508754USA	4"	2.5"
50875412		4.5"	3"
508755		5"	3"

<h1>CHANCE<sup>®</sup></h1>	<b>HUBBELL POWER SYSTEMS, INC.</b>			
	<small>POWER SYSTEMS, INC.</small> <b>TITLE</b> <b>SCREW, EZ DRIVE LAG</b>			
CONFIDENTIAL: THIS DRAWING AND ITS CONTENTS ARE CONFIDENTIAL AND THE EXCLUSIVE PROPERTY OF HUBBELL POWER SYSTEMS. NO PUBLICATION, DISTRIBUTION, OR COPIES MAY BE MADE WITHOUT THE WRITTEN CONSENT OF HUBBELL POWER SYSTEMS. HUBBELL POWER SYSTEMS UNPUBLISHED ALL RIGHTS RESERVED UNDER THE COPYRIGHT LAWS.	<small>SIZE</small> <b>B</b>	<small>CAT / PART / ASSY NO.</small> <b>SEE CHART</b>	<small>DWG NO.</small> <b>SA508754</b>	<small>REV</small> <b>D</b>
	<small>DO NOT SCALE THIS DRAWING</small>	<small>DRN BY</small> RWS	<small>DATE</small> 12/02/88	<small>SHEET</small> 1 OF 1