

==NOTE==

1. MAT'L: STEEL, HOT DIP GALVANIZED PER ASTM A153 LATEST REVISION.
2. FITS POLE FROM 6 INCHES TO 10-1/2 INCHES IN DIAMETER.

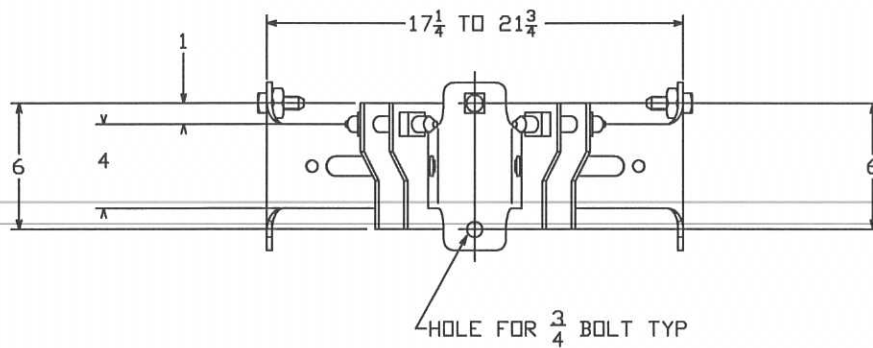
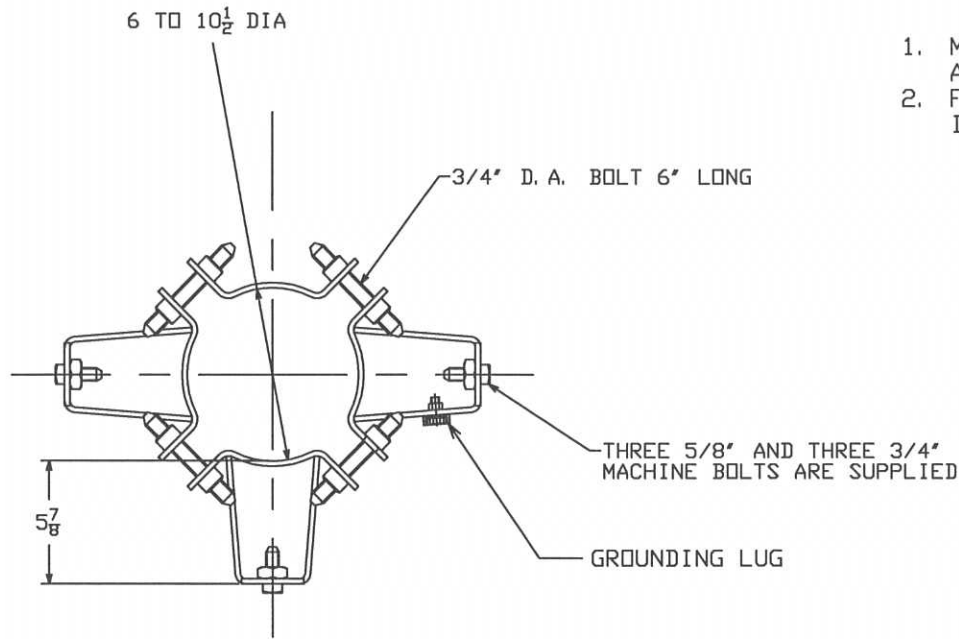

CAT. NO. 5350

CHANCE<sup>®</sup>  
TOLERANCE CHART

CONFIDENTIAL: THIS DRAWING AND ITS CONTENTS ARE CONFIDENTIAL AND THE EXCLUSIVE PROPERTY OF HUBBELL POWER SYSTEMS. NO PUBLICATION, DISTRIBUTION OR COPIES MAY BE MADE WITHOUT THE WRITTEN CONSENT OF HUBBELL POWER SYSTEMS. HUBBELL POWER SYSTEMS UNPUBLISHED ALL RIGHTS RESERVED UNDER THE COPYRIGHT LAWS.

HUBBELL<sup>®</sup> POWER SYSTEMS  
POWER SYSTEMS, INC.

TITLE  
TRANSFORMER  
MOUNTING BRACKET

SIZE	DWG NO.	CAT / PART / ASSY NO.	REV
SB	SA5350	5350	C
DO NOT SCALE THIS DRAWING	DRN BY WILSON	DATE 04/29/11	SHEET 1 OF 1