

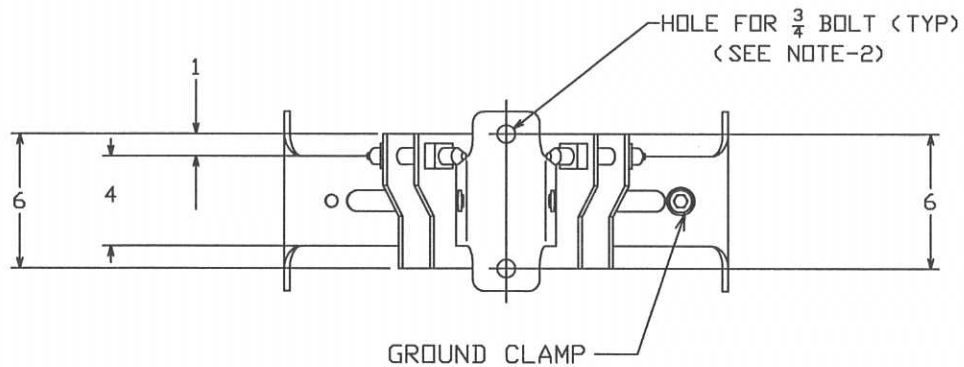

6 TO 12½ DIA

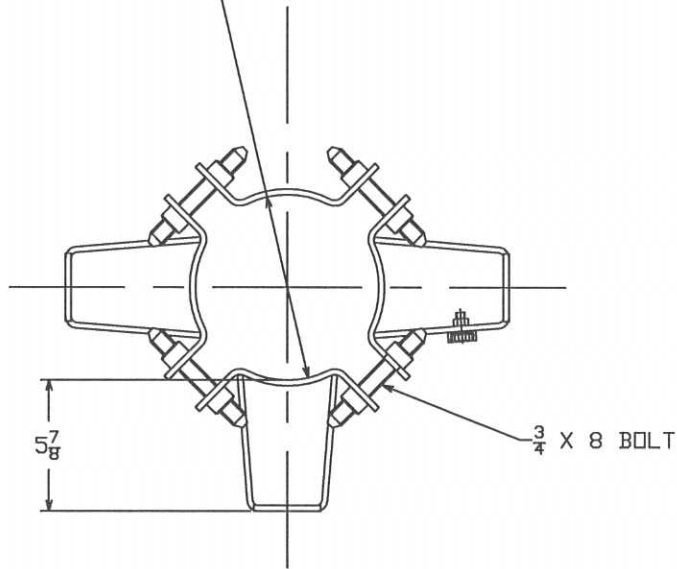

==NOTE==

1. MAT'L: STEEL, HOT DIP GALVANIZED PER ASTM A153 LATEST REVISION.
2. HARDWARE PACKAGED SEPERATELY INCLUDES 3 EACH OF:
 - 5/8 X 1.75 BOLT & NUT
 - 3/4 X 1.75 BOLT & NUT

CAT. NO. 5350-8

CHANCE TOLERANCE CHART		 HUBBELL POWER SYSTEMS POWER SYSTEMS, INC.	
CONFIDENTIAL: THIS DRAWING AND ITS CONTENTS ARE CONFIDENTIAL AND THE EXCLUSIVE PROPERTY OF HUBBELL POWER SYSTEMS. NO PUBLICATION, DISTRIBUTION OR COPIES MAY BE MADE WITHOUT THE WRITTEN CONSENT OF HUBBELL POWER SYSTEMS. HUBBELL POWER SYSTEMS UNPUBLISHED ALL RIGHTS RESERVED UNDER THE COPYRIGHT LAWS.		TITLE TRANSFORMER MOUNTING BRACKET	
SIZE	DWG NO.	CAT / PART / ASSY NO.	REV
SB	SA5350-8	5350-8	B
DO NOT SCALE THIS DRAWING	DRN BY WILSON	DATE 03/16/11	SHEET 01 OF 01