

=NOTE=

1. MAT'L: STEEL, HOT DIP GALVANIZED PER ASTM A153 LATEST REVISION.
2. ALL MAT'L IS UNASSEMBLED AND PACKAGED ONE PER CORRUGATED CARTON.
3. CATALOG NUMBER 53508BCH ONLY SUPPLIED WITH 3/4" HARDWARE.

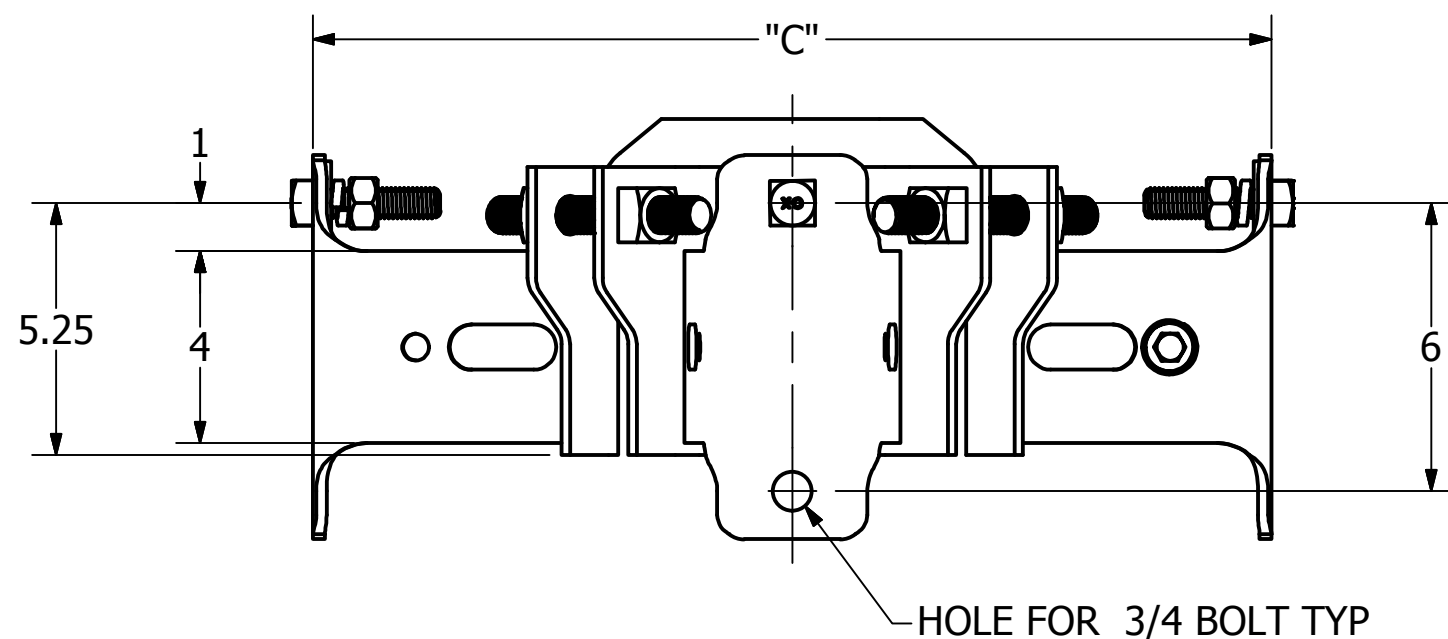

CATALOG NUMBER	"A"	"B"	"C"
5350BCH	6	6 TO 10.5	17.25 TO 21.75
53508BCH	8	6 TO 12.5	17.25 TO 23.75

<h1>CHANCE<sup>®</sup></h1>	<b>HUBBELL POWER SYSTEMS, INC.</b>								
	<b>TRANSFORMER MOUNTING BRACKET</b>								
CONFIDENTIAL: THIS DRAWING AND ITS CONTENTS ARE CONFIDENTIAL AND THE EXCLUSIVE PROPERTY OF HUBBELL POWER SYSTEMS. NO PUBLICATION, DISTRIBUTION, OR COPIES MAY BE MADE WITHOUT THE WRITTEN CONSENT OF HUBBELL POWER SYSTEMS. HUBBELL POWER SYSTEMS UNPUBLISHED ALL RIGHTS RESERVED UNDER THE COPYRIGHT LAWS.	<table border="1" style="width: 100%; font-size: x-small;"> <tr> <td>SIZE <b>B</b></td> <td>CAT / PART / ASSY NO. <b>SEE TABLE</b></td> <td>DWG NO. <b>SA5350BCH</b></td> <td>REV <b>A</b></td> </tr> <tr> <td>DO NOT SCALE THIS DRAWING</td> <td>DRN BY JMT</td> <td>DATE 4/22/19</td> <td>SHEET 1 OF 1</td> </tr> </table>	SIZE <b>B</b>	CAT / PART / ASSY NO. <b>SEE TABLE</b>	DWG NO. <b>SA5350BCH</b>	REV <b>A</b>	DO NOT SCALE THIS DRAWING	DRN BY JMT	DATE 4/22/19	SHEET 1 OF 1
SIZE <b>B</b>	CAT / PART / ASSY NO. <b>SEE TABLE</b>	DWG NO. <b>SA5350BCH</b>	REV <b>A</b>						
DO NOT SCALE THIS DRAWING	DRN BY JMT	DATE 4/22/19	SHEET 1 OF 1						