

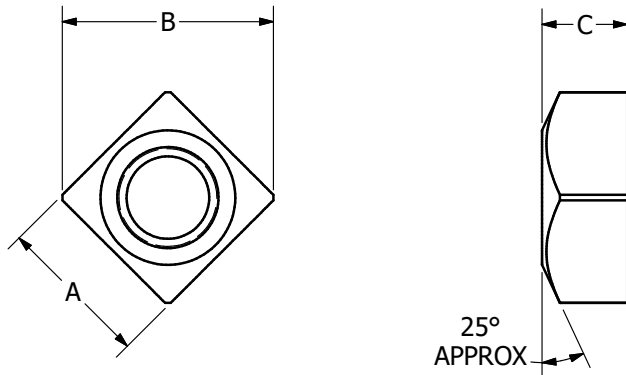

-NOTES-

1. ALL NUTS PER ASTM A563 GRADE A (GRADE 2).
2. NUTS ARE HOT DIP GALVANIZED PER ASTM A153 CLASS C (LATEST REV) AND THREADS ARE TAPPED AFTER GALVANIZING FOR GALVANIZED BOLTS.
3. NUTS MEET ALL REQUIREMENTS OF ANSI C135.1 (LATEST REV)
4. CATALOG NUMBERS WITH A "USA" SUFFIX HAVE ALL COMPONENTS MELTED AND MANUFACTURED IN THE USA.

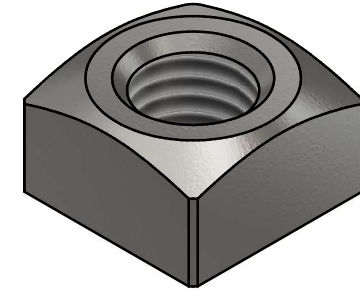

CATALOG NUMBER	THREAD	A	B	C
55058P	.578-12UNS	7/8	1.187	1/2
55006P	.695-11UNS	1-1/16	1.44	5/8
55312P	.828-10UNS	1-1/4	1.70	3/4
55320P	1.021-8UNS	1-5/8	2.215	1
56001P	1.271-7UNS	2	2.73	1-1/4

 THIS SYMBOL IDENTIFIES CRITICAL FEATURES

CHANCE ®	 HUBBELL POWER SYSTEMS, INC.			
	TITLE HEAVY SQUARE NUT			
CONFIDENTIAL: THIS DRAWING AND ITS CONTENTS ARE CONFIDENTIAL AND THE EXCLUSIVE PROPERTY OF HUBBELL POWER SYSTEMS. NO PUBLICATION, DISTRIBUTION, OR COPIES MAY BE MADE WITHOUT THE WRITTEN CONSENT OF HUBBELL POWER SYSTEMS. HUBBELL POWER SYSTEMS UNPUBLISHED ALL RIGHTS RESERVED UNDER THE COPYRIGHT LAWS.	SIZE	CAT / PART / ASSY NO.	DWG NO.	REV
	B	SA55320P	SA55320P	A
DO NOT SCALE THIS DRAWING	DRN BY MWW	DATE 7/28/23	SHEET 1 OF 1	